



# Foundry work

Level-II

# Learning Guide-13

**Unit of Competence:** Preparing Basic(2D) Engineering  
Drawing Using CAD

**Module Title:** Preparing Basic(2D) Engineering Drawing  
Using CAD

**LG Code:** IND FDW2 M04 LO1-LG-13

**TTLM Code:** IND FDW 2 M04 TTLM 1019v1

**LO 1: Identify drawing requirements**

Page 1 of 129	Federal TVET Agency Author/Copyright	Machining II Prepare Basic (2D) Engineering Drawing Using CAD	Version 1 October 2019
---------------	---	---	---------------------------



<b>Instruction Sheet</b>	<b>Learning Guide #13</b>
--------------------------	---------------------------

This learning guide is developed to provide you the necessary information regarding the following **content coverage** and topics:

- Determining specifications and other data.
- Identifying and analyzing necessary data of norm/ standards drawing.
- Verifying drawing requirements.

This guide will also assist you to attain the learning outcome stated in the cover page.

Specifically, **upon completion of this Learning Guide, you will be able to:**

- Specifications and other data are determined from work order and specification, actual sample or relevant documents
- All necessary data are identified and analyzed to produce the norm/ standards drawing
- Drawing requirements are verified by **relevant personnel** and timeframes for completion are established in accordance with standard operating procedures

### **Learning Instructions:**

1. Read the specific objectives of this Learning Guide.
2. Follow the instructions described below 3 to 50.
3. Read the information written in the information “Sheet 1, Sheet 2, and Sheet 3”.
4. Accomplish the “Self-check 1, Self-check t 2, and Self-check 3” **in page -10, 16 and 49** respectively.
5. If you earned a satisfactory evaluation from the “Self-check” proceed to “Operation Sheet 1, and Operation Sheet 3” **in page -51.**
6. Do the “LAP test” **in page – 52** (if you are ready).

<b>Information Sheet-1</b>	<b>Determining specifications and other data</b>
----------------------------	--

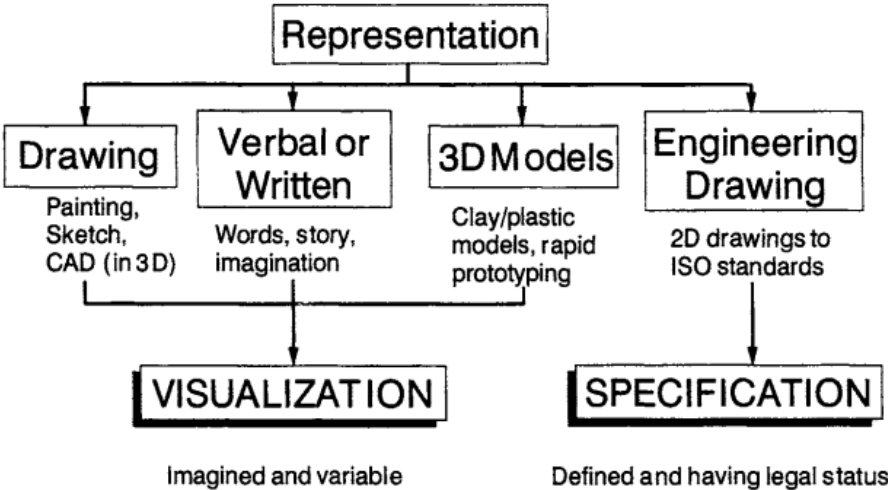
**1.1 Introduction**

Any language must be defined by a set of rules with regard to such things as sentence construction, grammar and spelling. Different languages have different rules and the rules of one language do not necessarily apply to the rules of another. A technical person can use the graphic language as powerful means of communication with others for conveying ideas on technical matters. However, for effective exchange of ideas with others, the engineer must have proficiency in (i) language, both written and oral, (ii) symbols associated with basic sciences and (iii) the graphic language. Engineering drawing is a suitable graphic language from which any trained person can visualize the required object. As an engineering drawing displays the exact picture of an object, it obviously conveys the same ideas to every trained eye.

**1.2. Representation, visualization and specification**

**1.2.1 Representation and visualization**

An artifact or system can be represented in a variety of ways. Engineering drawing is but one of the ways.



**Figure 1.1** Engineering drawing representation should be specification



Figure above shows some of the ways that products or systems can be represented. Verbal or written instructions take the form of words describing something. If the words take the form of a set of instructions for doing something, they are ideal. If the words are used to tell a story, then they can paint beautiful pictures in the imagination. However, words are clumsy with respect to transmitting information about an engineering artifact. Perhaps a chair or a table could be described without too much difficulty but for anything very much more complex, words become inadequate. Hence, the expression, a picture says a thousand words! Painting or sketching can certainly convey visual information.

### 1.2.2 Representation and specification

In Section 1.3, it was stated that engineering drawing was the equivalent of a language. A language has to have a set of rules and regulations for it to operate correctly. The same is true of engineering drawing. In the English language, there are two basic rules. The first is the word order that gives information on subject and object. The second is spelling, which gives information on the words themselves in terms of the spelling, i.e. the nouns, verbs, etc. Considering the word order, the phrase 'the cat sat on the mat' is very different from the phrase 'the mat sat on the cat'. All that has happened is that the words 'cat' and 'mat' have been swapped. Previously, the phrase described a perfectly feasible situation whereas it now describes an impossible situation. Thus, the word order gives information on which is the subject and which is the object. The second set of rules concern spelling and thus the phrase 'the cat sat on the mat' is very different from 'the bat sat on the mat' and yet this difference is the result of only one letter being changed!

In engineering drawing, there are similarly two sets of rules. The first also concerns order but in this case the order of the different orthographic views of an engineering artifact. The second is concerning how the individual views are drawn using different line thicknesses and line types, which is the equivalent of a spelling within each individual word. These are shown in Figure 1.8. The first set are the 'drawing layout rules', which define information concerning the projection method used and therefore the arrangement of the individual views and also the methodology concerning sections.

Page 4 of 129	Federal TVET Agency Author/Copyright	Machining II Prepare Basic (2D) Engineering Drawing Using CAD	Version 1 October 2019
---------------	---	---	---------------------------

The second set of rules is the 'manufacturing rules', which show how to produce and assemble an artifact. This will be in terms of the size, shape, dimensions, tolerances and surface finish. The drawing layout rules and the manufacturing rules will together make a legal specification that is binding. Both sets of rules are defined by ISO standards. When a contractor uses these two sets of rules to give information to a subcontractor on how to make something, each party is able to operate because of the underpinning provided by ISO standards.

### 1.3 Requirements of engineering drawings

Engineering drawings need to communicate information that is legally binding by providing a specification. Engineering drawings therefore need to meet the following requirements:

- Engineering drawings should be unambiguous and clear. For any part of a component there must be only one interpretation. If there is more than one interpretation or indeed there is doubt or fuzziness within the one interpretation, the drawing is incomplete because it will not be a true specification.
- The drawing must be complete. The content of an engineering drawing must provide all the information for that stage of its manufacture. There may be several drawings for several phases of manufacture, e.g. raw shape, bent shape and heat-treated. Although each drawing should be complete in its own right, it may rely on other drawings for complete specification, e.g. detailed drawings and assembly drawings.
- The drawing must be suitable for duplication. A drawing is a specification which needs to be communicated. The information may be communicated electronically or in a hard copy format. The drawing needs to be of a suitable scale for duplicating and of a sufficient scale such that if it is micro-copied it can be suitable magnified without loss of quality.
- Drawings must be language-independent. Engineering drawings should not be dependent on any language. Words on a drawing should only be used within the title block or where information of a non-graphical form needs to be given. Thus, there is a trend within ISO to use symbology in place of words.

- Drawings need to conform to standards. The 'highest' standards are the ISO ones that are applicable worldwide. Alternatively standards applicable within countries may be used. Company standards are often produced for very specific industries.

## 1.4 Sizes and layout of drawing sheets

### 1.4.1 Drawing paper size

Main article: Paper size

Sizes of drawings typically comply with either of two different standards, ISO (World Standard) or

(American), according to the following tables:

#### ISO PAPER SIZES (COMMON)

ISO A Drawing Sizes (mm)	
<b>A4</b>	210 X 297
<b>A3</b>	297 X 420
<b>A2</b>	420 X 594
<b>A1</b>	594 X 841
<b>A0</b>	841 X 1189

## 1.4.2 Layout of drawing

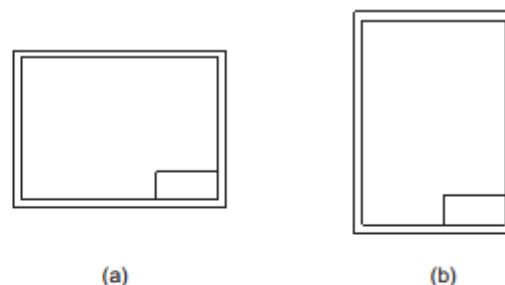
### 1.4.2.1 Title Block

The title block should lie within the drawing space such that, the location of it, containing the identification of the drawing, is at the bottom right hand corner. This must be followed, both for sheets positioned horizontally or vertically (Fig. 2.2).

The direction of viewing of the title block should correspond in general with that of the drawing. The title block can have a maximum length of 170 mm. Figure 2.3 shows a typical title block, providing the following information:

- (i) Title of the drawing
- (ii) Sheet number
- (iii) Scale
- (iv) Symbol, denoting the method of projection
- (v) Name of the firm
- (vi) Initials of staff drawn, checked and approved.

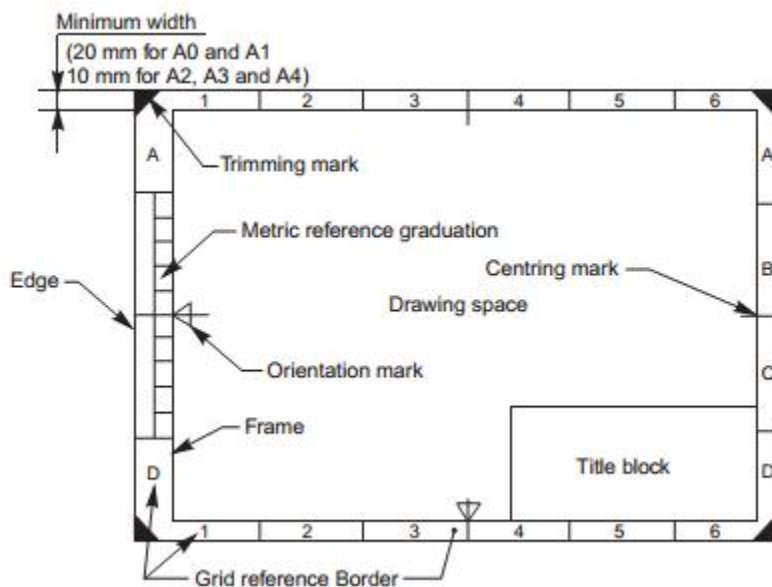
**NOTE** According to Bureau of Indian Standards, SP-46:1998, "Engineering Drawing Practice for Schools and Colleges", First angle projection is preferred.



**Fig. 2.2** Location of title block

### 1.4.2.2 Border line










Borders enclosed by the edges of the trimmed sheet and the frame, limiting the drawing space, should be provided with all sheet sizes. It is recommended that these borders have a minimum width of 20 mm for the sizes A0 and A1 and a minimum width of 10 mm for the sizes A2, A3 and A4 (see Fig. below). A filing margin for taking perforations, may be provided on the edge, far left of the title block.



### 1.4.2.3 Lines

Lines of different types and thicknesses are used for graphical representation of objects. The types of lines and their applications are shown in below.



<i>Line</i>	<i>Description</i>	<i>General Applications</i>
A 	Continuous thick	A1 Visible outlines
B 	Continuous thin (straight or curved)	B1 Imaginary lines of intersection B2 Dimension lines B3 Projection lines B4 Leader lines B5 Hatching lines B6 Outlines of revolved sections in place B7 Short centre lines
C 	Continuous thin, free-hand	C1 Limits of partial or interrupted views and sections, if the limit is not a chain thin
D 	Continuous thin (straight) with zigzags	D1 Line (see Fig. 2.5)
E 	Dashed thick	E1 Hidden outlines
G 	Chain thin	G1 Centre lines G2 Lines of symmetry G3 Trajectories
H 	Chain thin, thick at ends and changes of direction	H1 Cutting planes
J 	Chain thick	J1 Indication of lines or surfaces to which a special requirement applies
K 	Chain thin, double-dashed	K1 Outlines of adjacent parts K2 Alternative and extreme positions of movable parts K3 Centroidal lines



<b>Self-Check -1</b>	<b>Written Test</b>
----------------------	---------------------

**Directions:** Answer all the questions listed below. Use the Answer sheet provided in the next page:/Each point 1/

Say true if the statement is true and false if the statement is false.

1. A technical person uses the graphic language.
2. Words are clumsy with respect to transmitting information about an engineering artifact.
3. Engineering drawing hasn't a set of rules and regulations for it to operate correctly.
4. Lines of different types and thicknesses are used for graphical representation of objects.
5. Objects lines are not visible.

**Note: Satisfactory rating - 3 and 5 points**

**Unsatisfactory - below 3 and 5 points**

You can ask you teacher for the copy of the correct answers.



## Answer Sheet

Score = \_\_\_\_\_

Rating: \_\_\_\_\_

Name: \_\_\_\_\_

Date: \_\_\_\_\_

### Short Answer Questions

1.

2.

3.

4.

5.

<b>Information Sheet-2</b>	<b>Identifying and analyzing necessary data of norm/ standards drawing</b>
----------------------------	--

**2.1 Conventional representation of material:**

Certain draughting conventions are used to represent materials in section and machine elements in engineering drawings.

**Materials:**

As a variety of materials are used for machine components in engineering applications, it is preferable to have different conventions of section lining to differentiate between various materials. The recommended conventions in use are shown in Fig. below.

Type	Convention	Material
Metals		Steel, Cast Iron, Copper and its Alloys, Aluminium and its Alloys, etc.
		Lead, Zinc, Tin, White-metal, etc.
Glass		Glass
Packing and Insulating material		Porcelain, Stoneware, Marble, Slate, etc.
		Asbestos, Fibre, Felt, Synthetic resin products, Paper, Cork, Linoleum, Rubber, Leather, Wax, Insulating and Filling materials, etc.
Liquids		Water, Oil, Petrol, Kerosene, etc.
Wood		Wood, Plywood, etc.
Concrete		A mixture of Cement, Sand and Gravel

Fig. Conventional representation of material

## Machine components:

When the drawing of a component in its true projection involves a lot of time, its convention may be used to represent the actual component. Figure below. shows typical examples of conventional representation of various machine components used in engineering drawing.

Title	Subject	Convention
Straight knurling		
Diamond knurling		
Square on shaft		
Holes on circular pitch		
Bearings		
External screw threads (Detail)		
Internal screw threads (Detail)		
Screw threads (Assembly)		

Conventional representation of machine components ( Contd .)

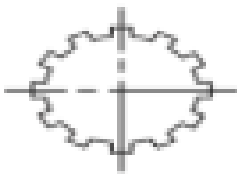
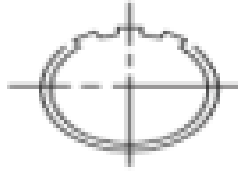
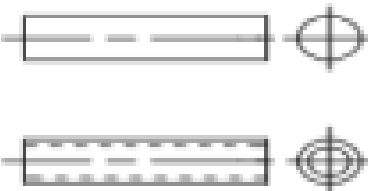
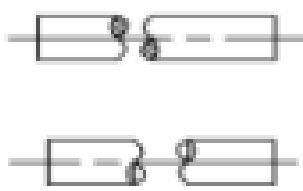
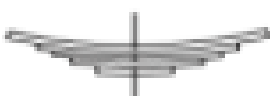
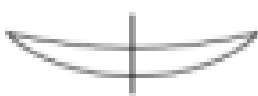
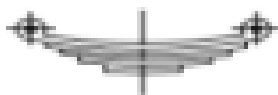
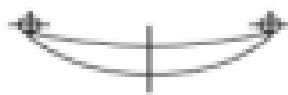
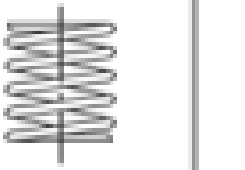
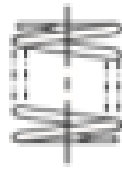
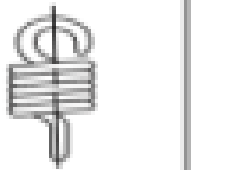

Title	Subject		Convention
Splined shafts			
Interrupted views			
Semi-elliptic leaf spring			
Semi-elliptic leaf spring with eyes			
	Subject	Convention	Diagrammatic Representation
Cylindrical compression spring			
Cylindrical tension spring			

Fig. 10

Conventional representation of machine components ( Contd .)


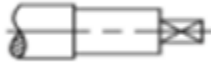


Title	Convention
Spur gear	
Bevel gear	
Worm wheel	
Worm	

**Fig. Conventional representation of machine components**

<b>Self-Check -2</b>	<b>Written Test</b>
----------------------	---------------------

**Directions:** Answer all the questions listed below. Use the Answer sheet provided in the next page:

**Matching the column A to column B**

- |  |  |
|--|--|
| <p style="text-align: center;">A</p> <p>1.</p>  <p>2.</p>  <p>3.</p>  <p>4.</p>  | <p style="text-align: center;">B</p> <p>A. Glass</p> <p>B. Square on shaft</p> <p>C. Splined shaft</p> <p>D. Spur gear</p> |
|--|--|

**Note: Satisfactory rating - 2 and 4 points**

**Unsatisfactory - below 2 and 4 points**

You can ask you teacher for the copy of the correct answers.





## Answer Sheet

Score = \_\_\_\_\_

Rating: \_\_\_\_\_

Name: \_\_\_\_\_

Date: \_\_\_\_\_

### Short Answer Questions

- 1.
- 2.
- 3.
- 4.

### 3.1. Drawing symbols and standards

#### 3.1.1 SYMBOLS

##### 3.1.1 Basic symbol

The basic symbol is shown in Figure 3.1. The dimensions of surface texture symbols are shown in Figure 3.2. Sloping lines in the symbol are at 60° to the horizontal.

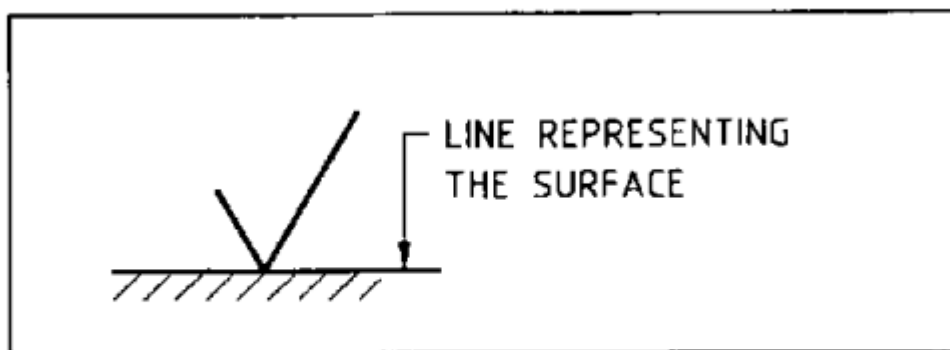
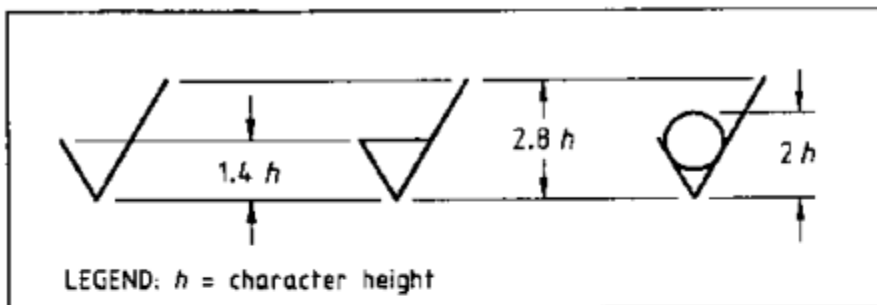


FIGURE 3.1 BASIC SYMBOL



$h$	$1.4h$	$2h$	$2.8h$
2.5	3.5	5.0	7.0
3.5	5.0	7.0	10
5.0	7.0	10	14
7.0	10	14	20
10	14	20	28
14	20	28	40
20	28	40	56

\* These figures are rounded upwards.

NOTE:  $h$  = character height

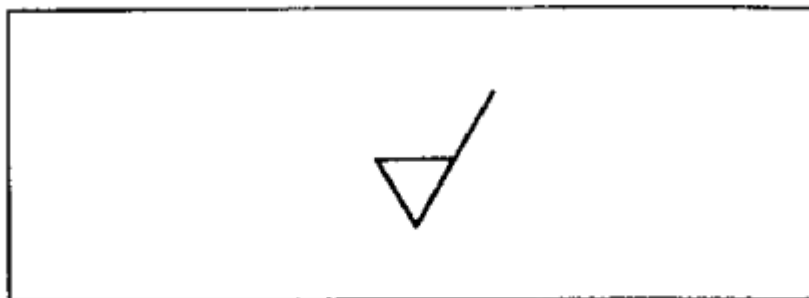
FIGURE 3.2 SHAPE AND SIZE OF SURFACE TEXTURE SYMBOLS

### 3.2.2 Modification to basic symbol

The following modifications may be made to the basic symbol:

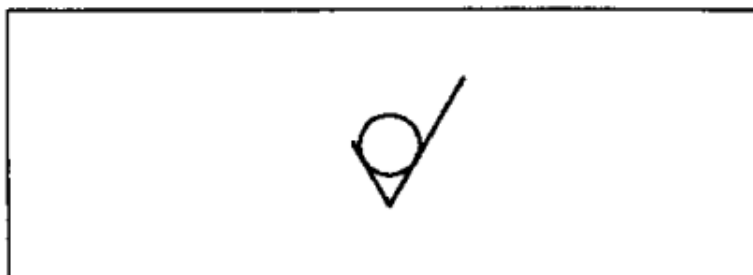
- The symbol to be used where machining is mandatory shall be the basic symbol with a bar added, as shown in Figure 3.3.

This symbol may be used alone to indicate that a surface is to be machined without defining either the surface texture or the process to be used.



**FIGURE 3.3 SYMBOL WHEN MACHINING IS MANDATORY**

(b) The symbol to be used when the removal of material is not permitted shall be the basic symbol with a circle added, as shown in Figure 3.4. This symbol may be used alone to indicate that a surface is to be left in the state resulting from a preceding manufacturing process.



**FIGURE 3.4 SYMBOL WHEN MATERIAL REMOVAL IS NOT PERMITTED**

**3.2.3 Extension of symbols** When special surface characteristics are to be indicated (see Clause 3.4), the symbols shown in Figures 3.1, 3.3 and 3.4 may be extended by adding a line of appropriate length to the long leg, as shown in Figure 3.5.

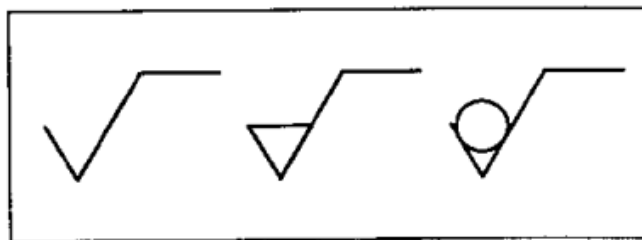


FIGURE 3.5 EXTENSION FOR SYMBOLS FOR SPECIAL SURFACE CHARACTERISTICS

## 1.3.2. Types and uses of drafting equipment and drawing instruments

### Basic Instruments and Materials

#### Introduction

The ability to visualize quickly and accurately the size of objects when drawn at a small scale is tremendous importance to the designer and must be acquired and continually applied before the draftsman can hope to accomplish much. As soon as the scale of the drawing is known, it can easily identify the instruments and material to be use for a particular drawing.

Engineering drawing instruments allow drafters to produce precise drawings. Technical drawing instruments are the tools used by professional and student drafters to render the precision graphics needed to manufacture a product or structure.

These instruments take many forms because of the variety of lines and graphics needed for designs. Some instruments are manual, while others are computer-based. All professional quality drafting instruments are manufactured with precision because the drawings they're used to make must be precise.

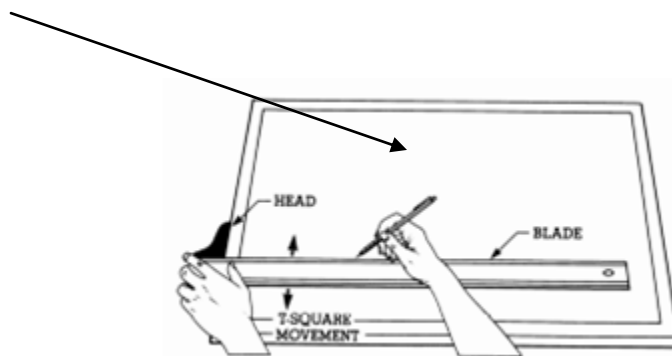
The following information assumes a right-handed drafter. Wherever "left" or "right" is written, the opposite direction may be substituted to apply to a left-handed drafter.

## DRAWING INSTRUMENTS AND MATERIALS

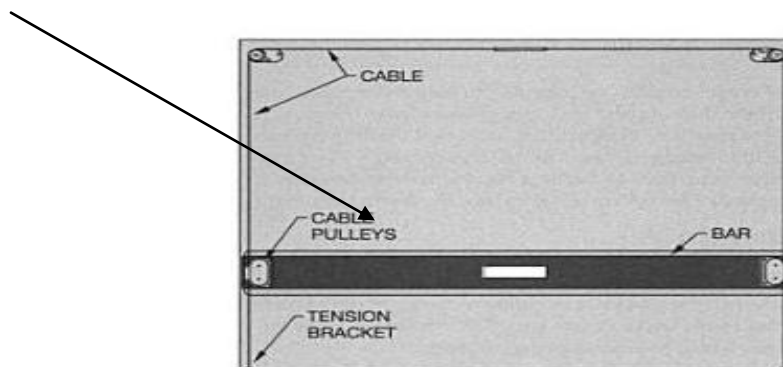
### Drawing Table



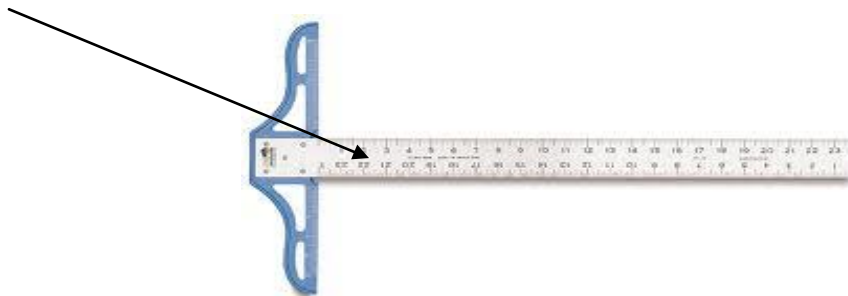
### Drawing Board



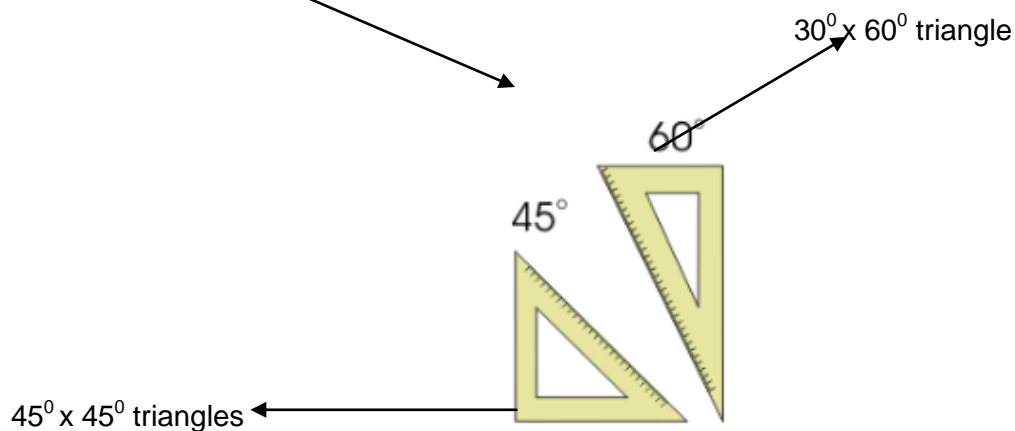
### Parallel Bar



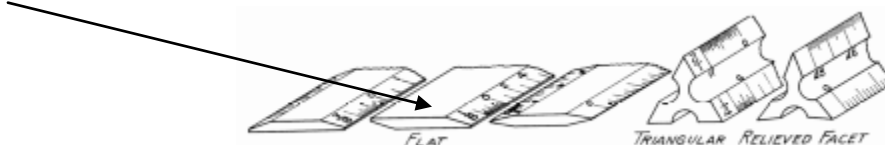
**T-Square**



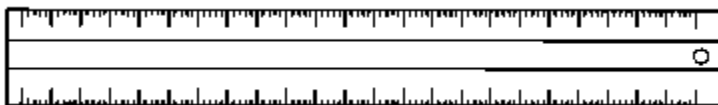
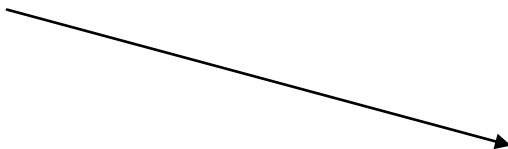
**Set Squares**



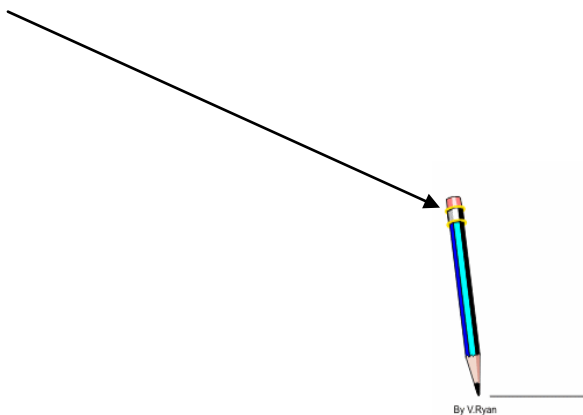
**Scale**



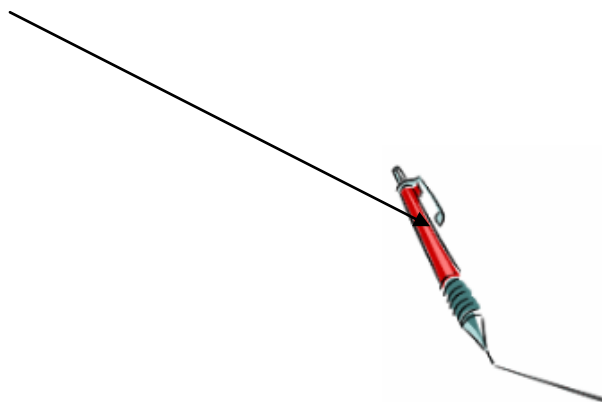
**Ruler**



**Drawing Pencil**

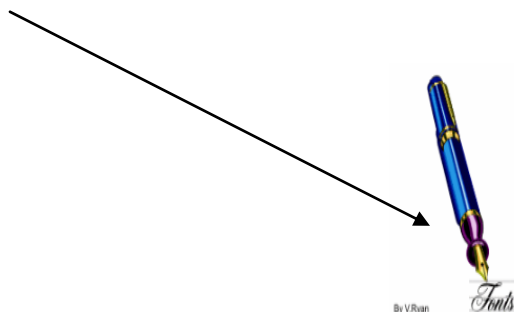


**Refillable pencil**

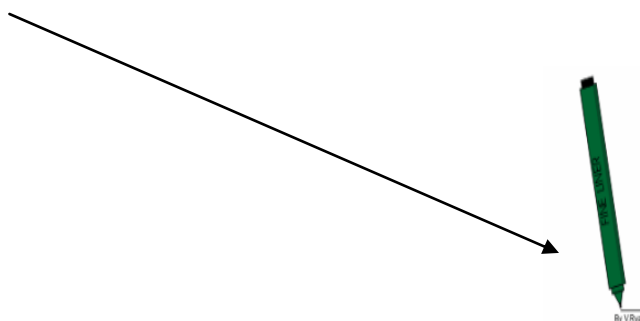




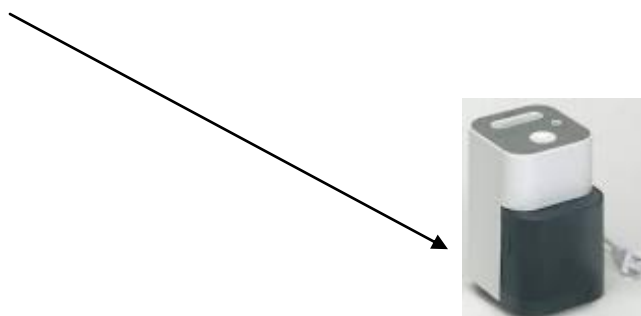
**Ink fountain pen**



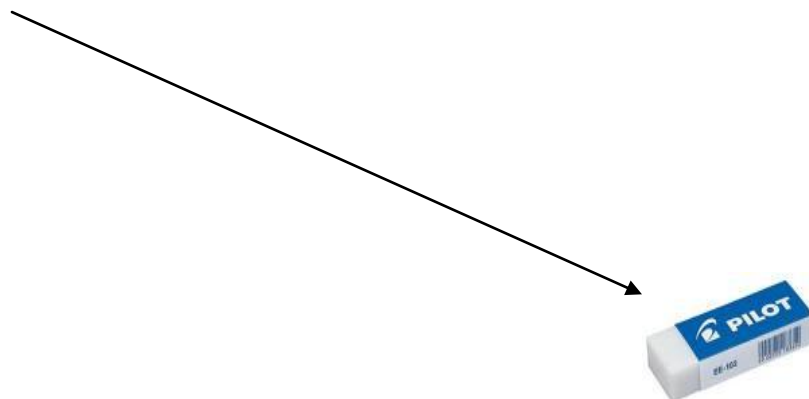
**Fine pen**



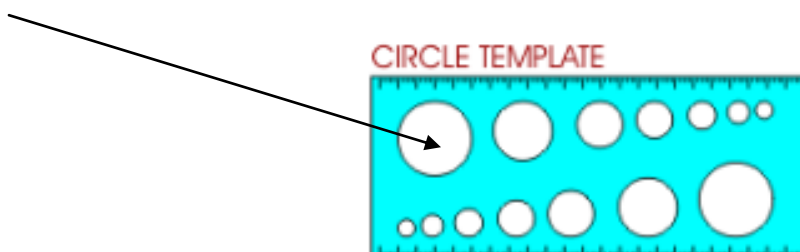
**Pencil sharpener**



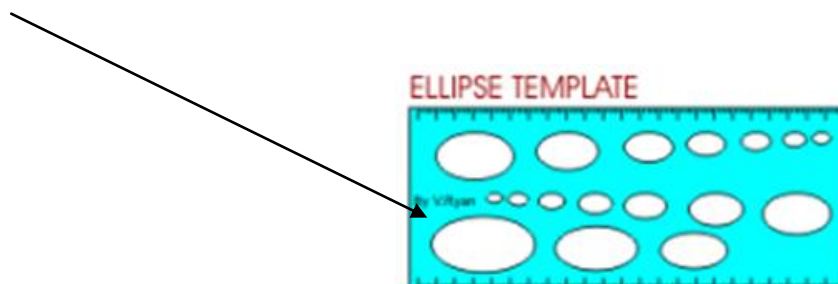
**Eraser**



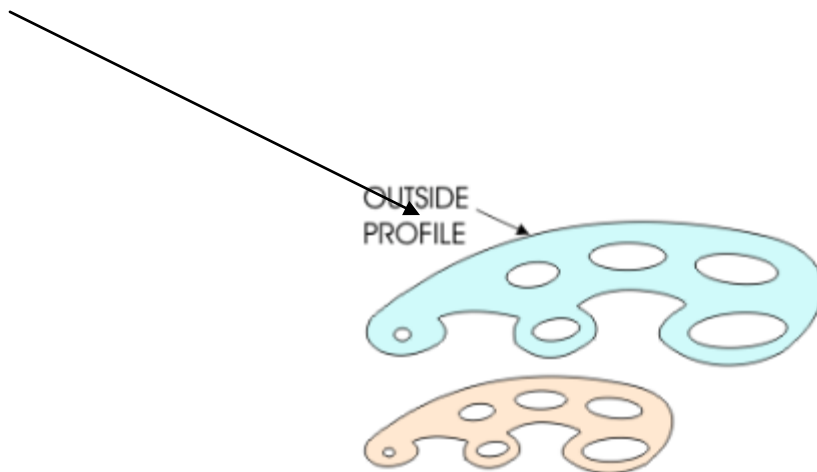
**Circle template**



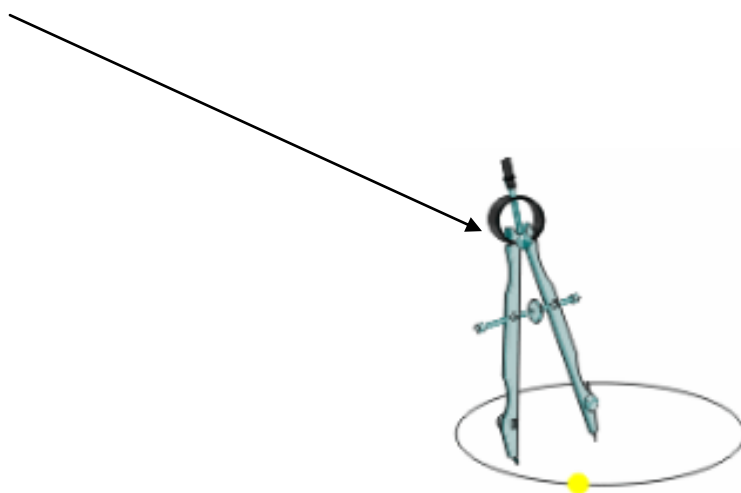
**Ellipse template**



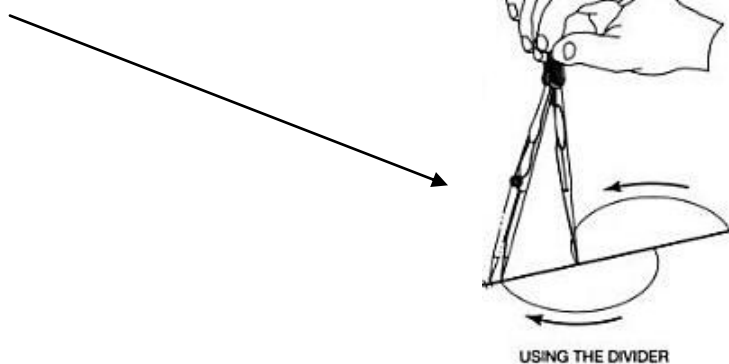
**French Curve**



**Compass**



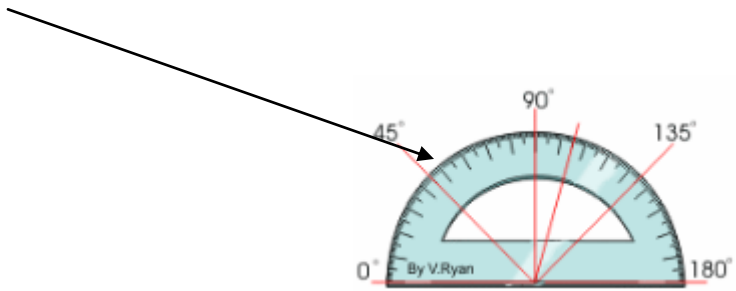
**Divider**



**Compass Adapter**



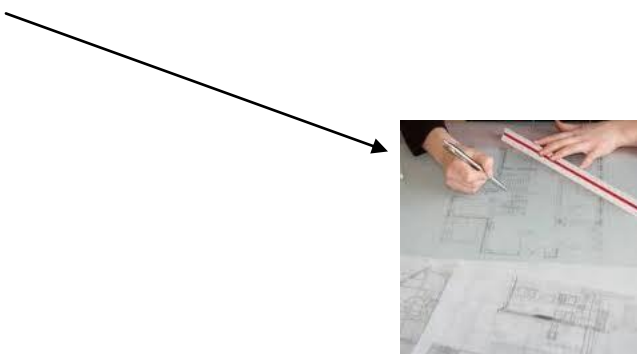
**Protractor**



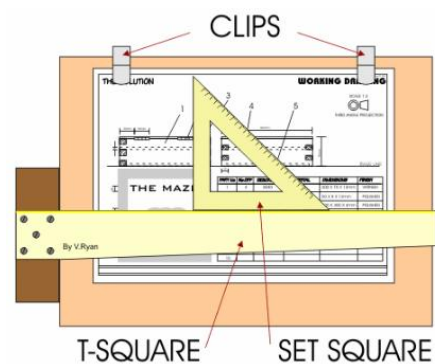
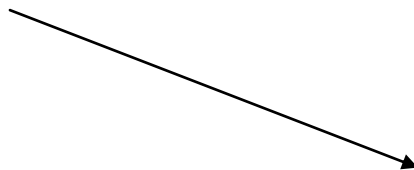
**Paper sizes**

SIZE (MILLIMETERS)		LETTER SIZE
WIDTH	LENGTH	
210	x 297	A4
297	x 420	A3
420	x 594	A2
594	x 841	A1
841	x 1189	A0

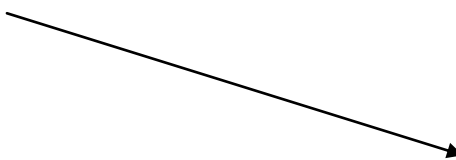
**Tracing paper**



**Board clips**



**Masking Tape**



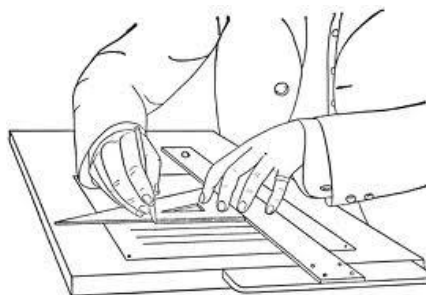
- **Description of drawing instruments and materials.**

### **Drawing Table/Board**

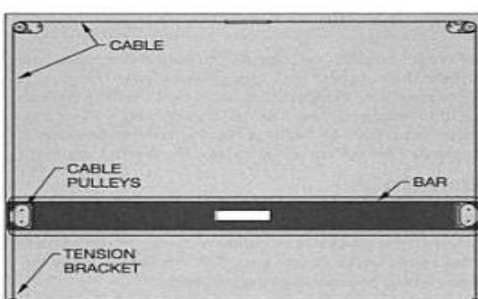
This has different dimensions that depends on the needs of a drafter. This should be a perfectly smooth flat board of soft wood or metal are made in such a way that it cannot warp or split. All angles should be perfectly true and smooth. The drawing board should be smooth and free from any hard particle.



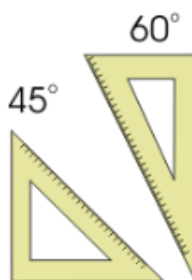
**T-Square** are especially useful when constructing accurate orthographic drawings or architectural drawings. A T-Square is normally used with a drawing board, set squares and clips. The common parts of a T-square are the head and the blade. The common materials to produce T-square are wood, plastic and metal. The substitute of a T-square is a slider which is shown on the figure upper right.



**Parallel bar** this bar will slides up and down the board to allow you to draw horizontal lines. Vertical lines and angles are made with triangles in conjunction with the parallel bar. The parallel bar is commonly found in architectural drafting offices because architectural drawings are frequently very large. Architects often need to draw straight lines the full length of their boards and the parallel bar is ideal for such lines.

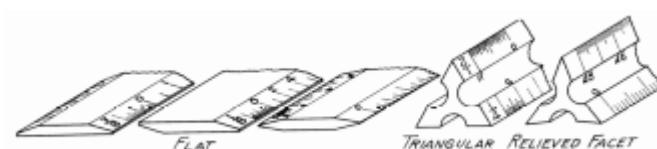


**Set Squares** The most common are 45 by 45 degrees and 60 by 30 degrees. When using set squares they should always used along with a T-Square. The Set-square rest on the straight edge of the T-Square and this ensures when the angle is drawn that it is accurate. Please see figure above.

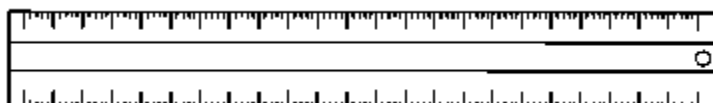




**Scale** The architectural draftsman's scale is made in various lengths, but 12 -inch triangular scale will be found best for student use. This has in one face the normal full size division of the foot. The scale at which the drawing is to be made may depend upon three things: first the size of the paper on which the draftsman wishes to work; second the size of the building or detail to be drawn; third, the amount of detail that is desirable to show in the drawing.



A **ruler** is possibly one of the most important pieces of drawing equipment. Be remembered that the edge of a ruler is not guaranteed to have a perfectly straight edge unlike a good T-Square or set square. The recommended material for a ruler is a plastic but for cutting purpose, it is advisable to use a metal ruler. Recommended maximum dimension of a ruler is 12 inches and it is commonly known as one foot ruler.



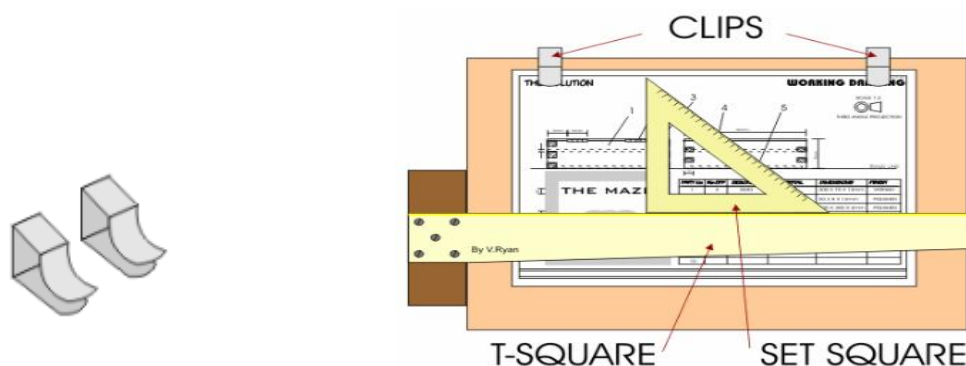
**Paper sizes** The rolls vary in width from 36 to 54 inches and contain a measurement from 10 to 50 yards. A 36 inch roll may be cut without waste into sheets 36 by 26, 26 by 18, 18 by 13, 13 by 9 by 6 1/2 inches.

SIZE (MILLIMETERS)		LETTER SIZE
WIDTH	LENGTH	
210	x 297	A4
297	x 420	A3
420	x 594	A2
594	x 841	A1
841	x 1189	A0

**Tracing paper** is a thin white transparent paper for general use where one drawing is to be made over another. But if ink was applied then you cannot use again. These material is recommended to use in preparation of plans and specifications.



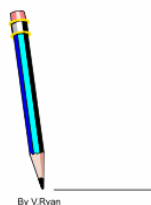
**Board clips** They simply clip on to the board holding the paper firmly against the drawing board. You can choose either plastic or metal clips. Figure below shows the importance of a board clips.



**Pencil sharpener** is an essential for sharpening pencils. Accurate drawings cannot be produced unless they are sharp. However, when shading a blunt pencil is sometimes useful. This is an electrical pencil sharpener and it is a heavy duty. Very precise and sensitive pencil sharpener. Be very carefull in dealing with it so that it will not consume your pencil easily.



**Drawing Pencils** are a basic requirement of any graphics course. You need a number ranging from 2B to 2H. These letters refer to the hardness of the pencil lead. When sketching a soft lead such as 2B is can be used to produce quick drawings and shading. On the other hand , when drawing precisely a 2H or even a harder pencil such as a 4H is ideal. This type of pencil keeps its sharp edge for longer and produces very fine lines.



A **refillable pencil** is very convenient to use if you are constructing a drawing that needs a constant thickness of line. The refills are available in a range of thicknesses and either hard or soft leads. Disadvantages are that the refillable pencils are relatively expensive and so are the refills. Also, the leads tend to break more easily.



**Ink fountain pens** Often the pens can be bought with a variety of ‘nibs’ as a set. These can be used to draw / write in a vast range of styles. This type of writing is called ‘Calligraphy’. Ink pens are rarely used now as word processing software can be used to produce accurate styles of writing in a range of fonts.



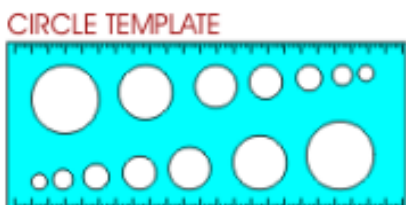
A **fine pen** (color - normally black) produce accurate lines. Fine pens are available with various thicknesses of 'tips'. They are especially useful for printing and placing notes alongside designs and sketches.



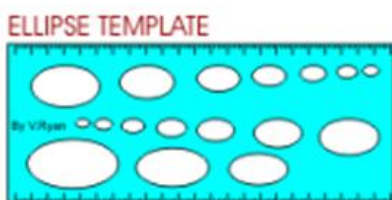
**Eraser** is a soft and a consumable materials. There are two kinds of it, an eraser for pencil and an eraser for ink pen.



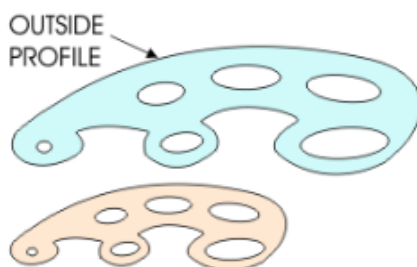
**Circle templates** They are plastic with a number of accurate circles cut out. Small circles are difficult to draw using a traditional compass because the compass can easily slip on the paper. With a template, the circle diameter is selected and a sharp pencil is used to draw round the cutout circle. If these material is being used properly can produce precision on making circles but it is limited only for small diameter.



**Ellipse templates** The description is similar to circle templates and these material can produce precise outcome for drawing ellipse / oval shapes accurately.



**French Curves** are purchased in sets of three or four. These can be used in the same way as circle or ellipse templates. This will create an irregular curve shape.



A **compass** is an absolute essential piece of equipment. It is well worth buying a good set which includes at least two compasses allowing the drawing of small and large circles. The drawing opposite is a 'bow' compass. This is very effective in making big diameter of a circle and curves.

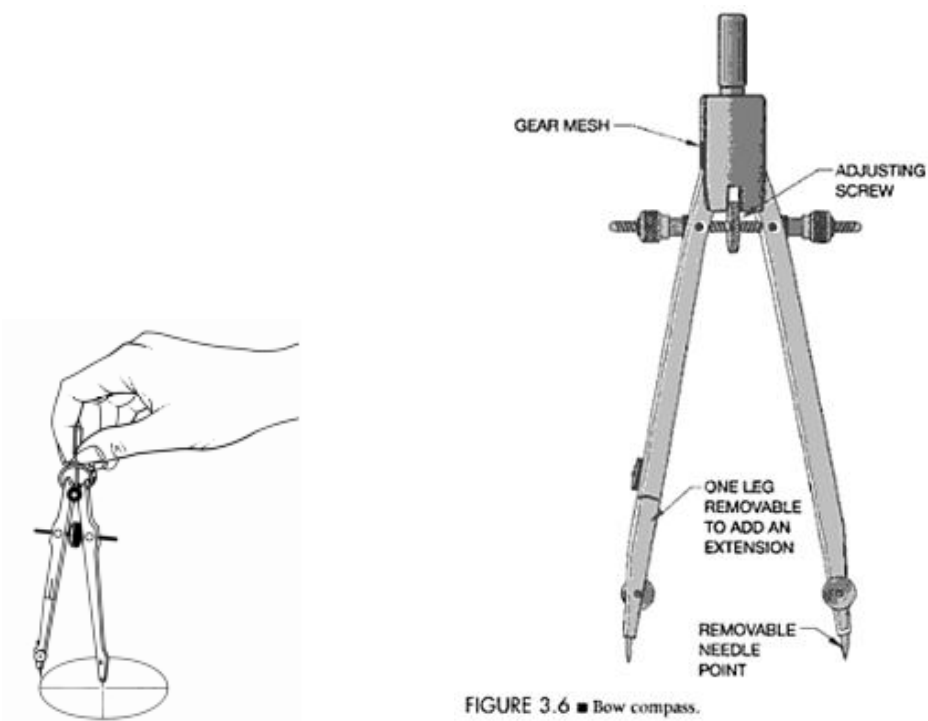
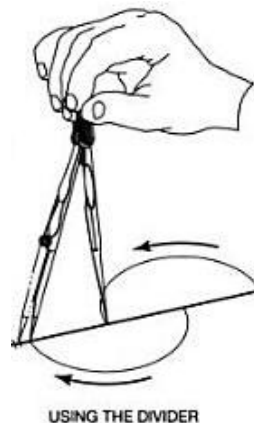
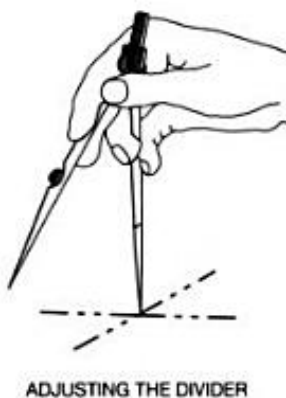


FIGURE 3.6 ■ Bow compass.

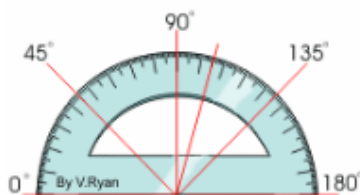
**Divider** is looks like a compass but it differs with its uses. Both ends are pointed, not like a compass the other end has an attachment of a lead pencil.



**Compass Adapter** is an attachment of a compass and effective for inking process.



A **protractor** is a typical protractor , a semi-circular piece of plastic with 180 degrees printed around its curve. These instrument is not advisable to draw curves. The purpose of these instrument is for determining angles only.



### Usage of Drawing Instruments and Materials

**Drawing Table/Board** is use in drafting or sketching objects or building. Any drafter cannot produce precise outcome drawing if you will not use a recommended drawing table. Drawing board is incline according to the convenience of a drafter. Do not use the drawing table for seating, eating or any undesirable manner.

**Parallel Bar** is the same usage of a T-square, but it is more convenient to use for it is fixed and easy to adjust.

**T-Square** is use to draw horizontal lines. They are especially useful when constructing accurate orthographic drawings or architectural drawings. A T-Square is normally used with a drawing board, set squares and clips. It must be pushed firmly against the edge of the drawing board when it is being used. If successive usage of T-square, a recommendation for cleaning is a must. To wipe out pencil residues and dirt molecules attached on the instrument cause of continuous friction. The proper usage of a T-square is to position the blade along the horizontal age of the board and not the vertical position.



**Set Squares** are used to draw accurate angles. When using set squares they should always be used along with a T-Square. The Set-square rests on the straight edge of the T-Square and this ensures when the angle is drawn that it is accurate. Apply pressure from your hand when using the set square. You can also draw lines vertically from the edge of the T-square.

**Scale** is used in converting of lines, objects or buildings from original size to the size that will fit on the drawing paper or tracing paper. Which it is convenient and readable for a draftsman or end user. The scale at which the drawing is to be made may depend upon three things: first the size of the paper on which the draftsman wishes to work; second the size of the building or detail to be drawn; third, the amount of detail that is desirable to show in the drawing. The usage of these instruments is very important in making floor plans.

A **ruler** is possibly one of the most important pieces of drawing equipment. Rulers should only be used to measure distances with lines being drawn with T-Squares and Set Squares. However, most people use rulers to draw straight lines. But it must be remembered that the edge of a ruler is not guaranteed to have a perfectly straight edge unlike a good T-Square or set square.

**Paper sizes** are very important materials to be distinguished and it is used for the drawing of details. For drawing exercises, recommended paper size is essential for a student to use to consider economical aspects.

**Tracing paper** is a thin white transparent paper for general use where one drawing is to be made over another. But if ink was applied then you cannot use again. This material is expensive and a beginner drafter or students are not advised to use this paper for practice purposes. Use only tracing paper for final presentation of your outcome drawing. Tracing paper is an important material for blue printing.

**Board clips** are used to hold the drawing paper in position. They simply clip on to the board holding the paper firmly against the drawing board. The disadvantage of using board clips is that they obstruct the movement of the T-square or the set squares in use during working drawing. Occasionally tear off the edge of the drawing paper if not properly detached after using the said material.

**Pencil sharpener** is used for sharpening pencils. You can use electrical and manual heavy duty pencil sharpeners. Be cautious in using these tools so that your pencil will not be consumed rapidly.

Page 40 of 129	Federal TVET Agency Author/Copyright	Machining II Prepare Basic (2D) Engineering Drawing Using CAD	Version 1 October 2019
----------------	---	---	---------------------------





**Drawing Pencils** is use to produce quick drawings and shading. On the other hand, when drawing precisely a 2H or even a harder pencil such as a 4H is ideal. This type of pencil keeps its sharp edge for longer and produces very fine lines. The proper way of using these instrument is to gradually roll the tip of the pencil as you go along drawing a line. The purpose of rolling the tip of your pencil is to maintain the thickness of your drawn line and also not to flatten the tip of the pencil and so that you can avoid successive sharpening of your pencil to avoid deterioration of your instrument.

**Refillable pencil** is very useful especially if you are constructing a drawing that needs a constant thickness of line. The refills are available in a range of thicknesses and either hard or soft leads.

**Ink fountain pen** can be used for producing 'fancy' styles of writing. Often the pens can be bought with a variety of 'nibs' as a set. These can be used to draw / write in a vast range of styles. This type of writing is called 'Calligraphy'. Ink pens are rarely used now as word processing software can be used to produce accurate styles of writing in a range of fonts.

**Fine pen** is use in final stage of your working drawing. A common concept in preparing drawing is using a fine pencil for you can easily edit when mistakes occurs, but when fine pen is applied then it is very difficult to erase though there is an eraser to use for it. Some marks is visible even erasure was being done. Fine pen ink is used to draw permanent, accurate and final drawing works. Fine pens are available with various thicknesses of 'tips'. They are especially useful for printing and placing notes alongside designs and sketches. They are also used for producing the final outline of a design.

**Erasers** are being used for cleaning off light lines or soiled places. Pencil outlines are very easy to wipe out and eventually not leaving any mark. For permanent markings, eraser for this purpose is recommended but sometimes leave markings and it will contribute bad image of your final result of your drawing work. Special eraser particles are available to help reduce smudging and to keep the drawing and your equipment clean. Use this material sparingly since too much can cause your lines to become fussy. Cleaning powders are not recommended for use on ink drawings.

Page 41 of 129	Federal TVET Agency Author/Copyright	Machining II Prepare Basic (2D) Engineering Drawing Using CAD	Version 1 October 2019
----------------	---	---	---------------------------



**Circle template** is use for drawing small circles and are difficult to draw it using a traditional compass because the compass can easily slip on the paper. With a template, the circle diameter is selected and a sharp pencil is used to draw round the cutout circle. These instrument is also recommended to use for final drawing or inking procedure.

**Ellipse template** is similar to circle templates and these material is useful for drawing ellipse / oval shapes accurately. Just make sure to observe distance of the tip of your pen from the edge of ellipse guide to avoid ink blots. This is also effective only on a small curvature.

**French Curves** are being used to draw curves by finding the section of curve that matches the desired shape on the profile of the curve. Some French Curves also have either circles or ellipses of various sizes cut out. These can be used in the same way as circle or ellipse templates especially in irregular curve outlines.

**Compass** is use for drawing big diameter circles very accurately. Sometimes compass can be used in drawing small circle but very often to commit error. It recommends more practice to obtain accuracy of these tool. Cheap compasses tend to slip on the paper and break quite easily. A good, quality compass set will last a life time. Compasses are used to draw circles and arcs. However, using a compass can be time consuming if small diameter of a circle is to be considered. A compass is especially useful for large circle or arcs. Keep both the compass needle point and lead sharp. The points are removable for easy replacement.

**Compass Adaptor** is use in your final drawing of circles or curves. These instrument is being attached in one leg of a compass and also a pen simultaneously.

**Dividers** are used to transfer dimensions or to divide a distance into a number of equal parts. It also step off equal distances or to divide a line or space into equal parts. Observed strictly that do not try to use dividers as a compass. A good divider should not be too loose or too tight. It should be easily adjustable with one hand. In fact, you should control a divider with one hand as you lay out equal increments or transfer dimensions from one feature to another.

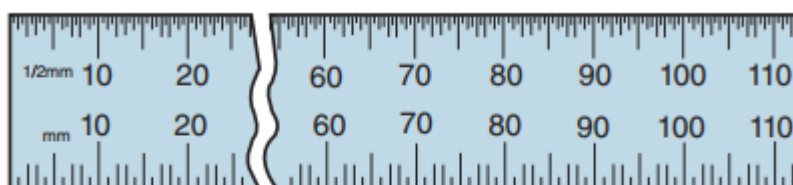
**Protractor** is use to measure angles. This piece of instrument is not only used in graphics for constructing accurate drawings but is also used in subjects like Mathematics.

Page 42 of 129	Federal TVET Agency Author/Copyright	Machining II Prepare Basic (2D) Engineering Drawing Using CAD	Version 1 October 2019
----------------	---	---	---------------------------

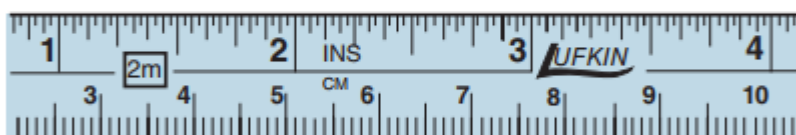
### 1.3.3. Using measuring instruments

Measuring tools are instruments used to determine lengths and angles. They follow two systems. They are the US customary system and the International System (SI), commonly referred to as metric. US customary rulers and scales measure feet and inches. Smaller units are measured in fractions of an inch.

#### A—US Customary Rule



#### B—Metric Rule

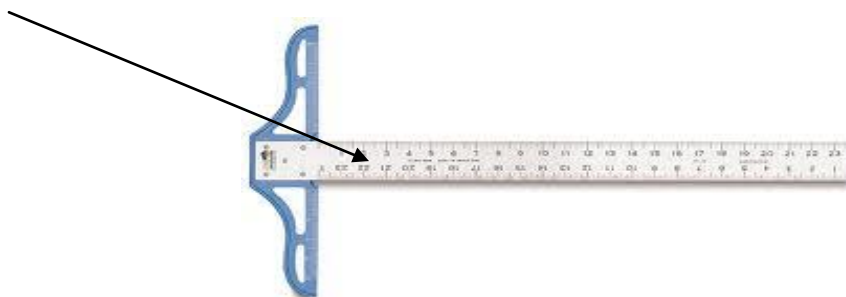


#### C—Combination Rule

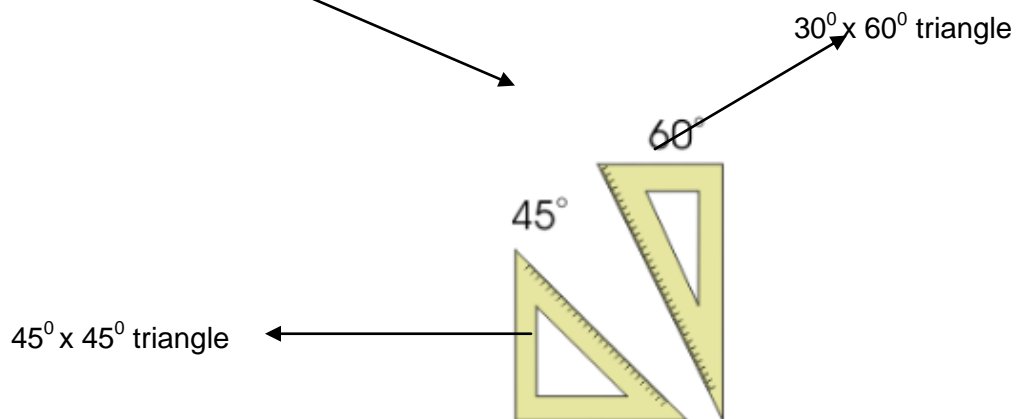
*Lufkin Division—The Cooper Group, The L. S. Starrett Co.*

**Figure** Rule measuring units. Use the system designated on the working drawings. A—US customary. B—Metric. C—Combination of both units.

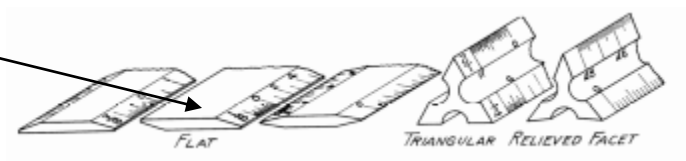
#### T-Square



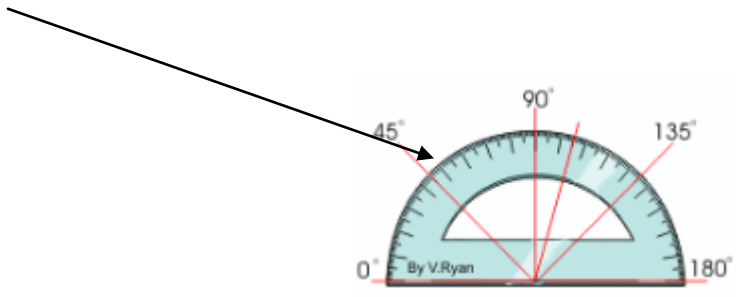
**Set Squares**



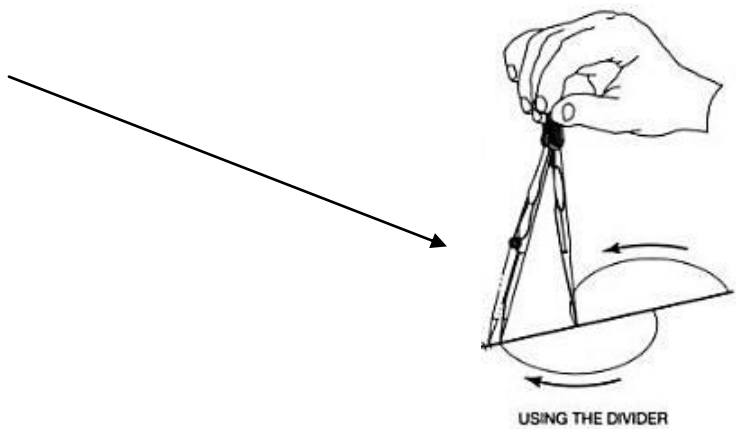
**Scale**



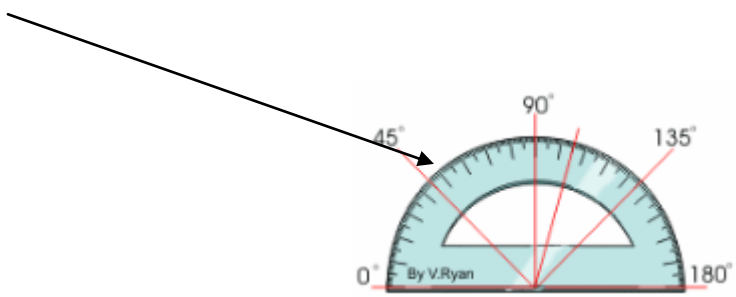
**Protractor**



**Divider**



**Protractor**



### 1.3.4 Establishing relevant personnel.

The trainee will be tested for his skill, knowledge and attitude during the period of the unit of competence and at the end of the training program as notified by the collage registrar. Then, a relevant personnel is instructor itself. By apply professional knowledge, core skills & performing the work. Assessment will be conducted using assessment criteria.

- Relevant personnel

May include, but is not limited to:

- ✓ Supervisor
- ✓ Technical personnel
- ✓ Manufacturers
- ✓ Suppliers
- ✓ Contractors
- ✓ Customers

#### **Definition of Supervision:**

“Supervision is getting the job done through others.”

This classic definition of supervision states the relationship between supervisors, subordinates, and work. However, it doesn't explain how to be a delegator, a decision maker, a coach, an instructor, a motivator, or most importantly, a leader. The skills of good supervision are new to most people when they are asked to lead for the first time. To be successful as a leader, the new supervisor needs to consider three broad areas:

#### **ADMINISTRATIVE:**

The new supervisor is accountable for many organizational procedures that subordinates don't have to consider. These include daily reports, monitoring time and attendance, budgeting, work orders, transmitting management directives and bulletins, and a host of other types of information.

#### **TECHNICAL:**

New supervisors have demonstrated their proficiency in technical skills in order to be promoted to supervision. However, as a leader becomes more involved in supervision, the amount of time available for doing technical tasks decreases and the amount of time



spent helping others increases. Supervisors eventually find themselves helping people with tasks that they themselves have never done.

### **INTERPERSONAL:**

Becoming an effective supervisor involves learning a whole set of leadership skills. Prior training both on the job and in school probably hasn't covered the interpersonal skills of leadership. New supervisors need to look to role models and mentors for tips on leadership behaviors. They also need to examine their own personal styles and consider the changes they need to make for their own growth and development. As an exercise in defining supervision, think about all the different tasks that are part of the supervisor's job. Make a list of these tasks on the next page and discuss them with your manager. Ask if you will actually be evaluated on how well or poorly you perform each task.

### **Supervisory Duties:**

#### **Planning and Organizing:**

Lay out the work and decide how to handle it.

#### **Processing the Work:**

Assign the work and supply what your employees need to get the job done.

#### **Controlling the Operation:**

Keep the work up to standards and check on costs and materials.

#### **Administering Rules:**

See that conduct and procedures are done according to the rules.

#### **Keeping People Informed:**

Talk with and listen to staff - up and down the line.

#### **Making Improvements:**

Find better ways for doing the work and solve job problems.

#### **Handling Personnel Matters:**

Administer leave time, benefits, pay, change of jobs, overtime, and other personnel functions.

#### **Training and Development:**

Break in new people, build morale, plan replacements.

Page 47 of 129	Federal TVET Agency Author/Copyright	Machining II Prepare Basic (2D) Engineering Drawing Using CAD	Version 1 October 2019
----------------	---	---	---------------------------



### **Monitoring Safety and Security:**

Prevent trouble. Deal with accidents and illnesses. Safeguard equipment and supplies.

### **Serving as Representative:**

Act for the group or the organization as required."

### **Manufacturers /Manufacturing Drawings/**

Manufacturing drawings communicate engineers' ideas in a clear way and inform machine operators and production workers how a certain product is manufactured and assembled. They're greatly important in the production process, but, due to their highly detailed nature, they require a lot of time and attention. Because of this, many engineers and entrepreneurs take advantage of the manufacturing drawing services we offer here at Cad Crowd. Our freelancers are experts in this type of illustrative material and can assist you in creating informative manufacturing drawings that comply with international standards.

Page 48 of 129	Federal TVET Agency Author/Copyright	Machining II Prepare Basic (2D) Engineering Drawing Using CAD	Version 1 October 2019
----------------	---	---	---------------------------



<b>Self-Check -3</b>	<b>Written Test</b>
----------------------	---------------------

**Directions:** Answer all the questions listed below. Use the Answer sheet provided in the next page:

**Match column A to column B.**

A

1. T-Square

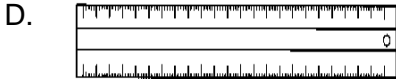
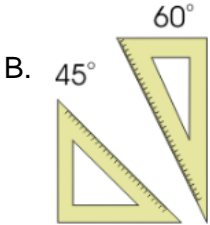
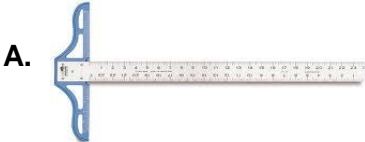
2. Set Squares

3. Scale

4. Ruler

5. Drawing Pencil

B



**Note: Satisfactory rating - 3 and 5 points**

**Unsatisfactory - below 3 and 5 points**

You can ask you teacher for the copy of the correct answers.



## Answer Sheet

Score = \_\_\_\_\_

Rating: \_\_\_\_\_

Name: \_\_\_\_\_

Date: \_\_\_\_\_

### Short Answer Questions

- 1.
- 2.
- 3.
- 4.
- 5.



<b>Operation Sheet- 1</b>	<b>Identify drawing requirements</b>
---------------------------	--------------------------------------

### **Techniques for drawing requirements**

**Step 1-** Requirements of engineering drawings need to communicate information

**Step 2-** Identify Sizes drawing paper

**Step 3 -** Identify layout of drawing sheets

**Step 4 -** Identify different types and thicknesses of lines

<b>Operation Sheet- 3</b>	<b>Verifying drawing requirements</b>
---------------------------	---------------------------------------

### **Techniques for verifying drawing requirements**

**Step 1-** Identify basic drawing symbols and standards

**Step 2-** Identify Basic Instruments and Materials

**Step 3 -** Identify measuring instruments of drawing

**Step 4 –** Assign relevant personnel

LAP Test	Practical Demonstration
----------	-------------------------

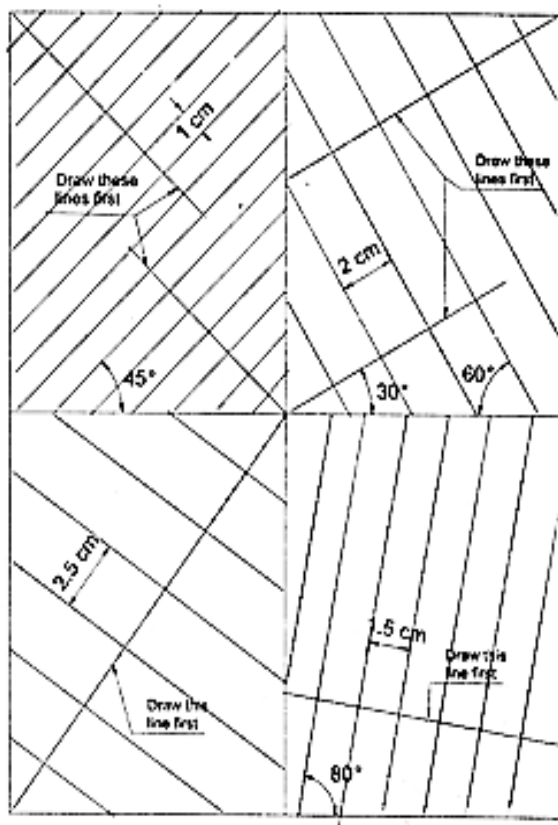
Name: \_\_\_\_\_ Date: \_\_\_\_\_

Time started: \_\_\_\_\_ Time finished: \_\_\_\_\_

**Instructions:** Given necessary templates, tools and materials you are required to perform the following tasks within 4 hours.

**Checkpoint 4 Drawing perpendicular and parallel lines**

1. Draw the border lines.
2. Divide the drawing space into four equal rectangles as shown in the figure below.
3. Draw all the lines that are indicated to be drawn first in all rectangles using the 5H pencil and mark the division points at the given distances on each line. Use the set-squares whenever possible and the protractor if not.
4. Draw lines perpendicular to the lines drawn first in step 3 using the set-squares and the H pencil. Omit all dimensions.



<https://www.youtube.com/watch?v=z4xZmBpXlZQ>



# Foundry work

## Level-II

# Learning Guide-14

**Unit of Competence:** Preparing Basic (2D) Engineering Drawing Using CAD

**Module Title:** Preparing Basic (2D) Engineering Drawing Using CAD

**LG Code:** IND FDW M04 LO2-LG-14

**TTLM Code:** IND FDW M04 TTLM 1019v1

**LO 2:** Prepare drawings or make changes to existing drawings

Page 53 of 129	Federal TVET Agency Author/Copyright	Machining II Prepare Basic (2D) Engineering Drawing Using CAD	Version 1 October 2019
----------------	---	---	---------------------------



This learning guide is developed to provide you the necessary information regarding the following **content coverage** and topics:

- Applying drafting principles.
- Indicating dimensions, notes and specifications
- Presenting complete drawings

This guide will also assist you to attain the learning outcome stated in the cover page. Specifically, **upon completion of this Learning Guide, you will be able to:**

- **Drafting principles** are applied to produce a drawing that is consistent with standard operating procedures
- Dimensions, notes and specifications are indicated in the drawing in accordance with drafting principles and standards
- Completed drawing is presented for approval in accordance with standard operating procedures
- Completed drawing is presented for approval in accordance with standard operating procedures

#### **Learning Instructions:**

7. Read the specific objectives of this Learning Guide.
8. Follow the instructions described below 55 to 82.
9. Read the information written in the information “Sheet 1, Sheet 2, and Sheet 3”.
10. Accomplish the “Self-check 1, Self-check 2, and Self-check 3” **in page -81, 95 and 100** respectively.
11. If you earned a satisfactory evaluation from the “Self-check” proceed to “Operation Sheet 1, and Operation Sheet 2” **in page -102.**
12. Do the “LAP test” **in page – 103** (if you are ready).

<b>Information Sheet-1</b>	<b>Applying drafting principles</b>
----------------------------	-------------------------------------

## 1.1. Applying drafting principles

### Introduction

Engineering drawings are to be prepared on standard size drawing sheets. The correct shape and size of the object can be visualized from the understanding of not only the views of it but also from the various types of lines used, dimensions, notes, scale, etc. To provide the correct information about the drawings to all the trainee, the drawings must be prepared, as the following certain standard practices.

#### 1.1.1. Drafting principles to be applied in the preparation of drawing

- **Drawing sheet**

Engineering drawings are prepared on drawing sheets of standard sizes.

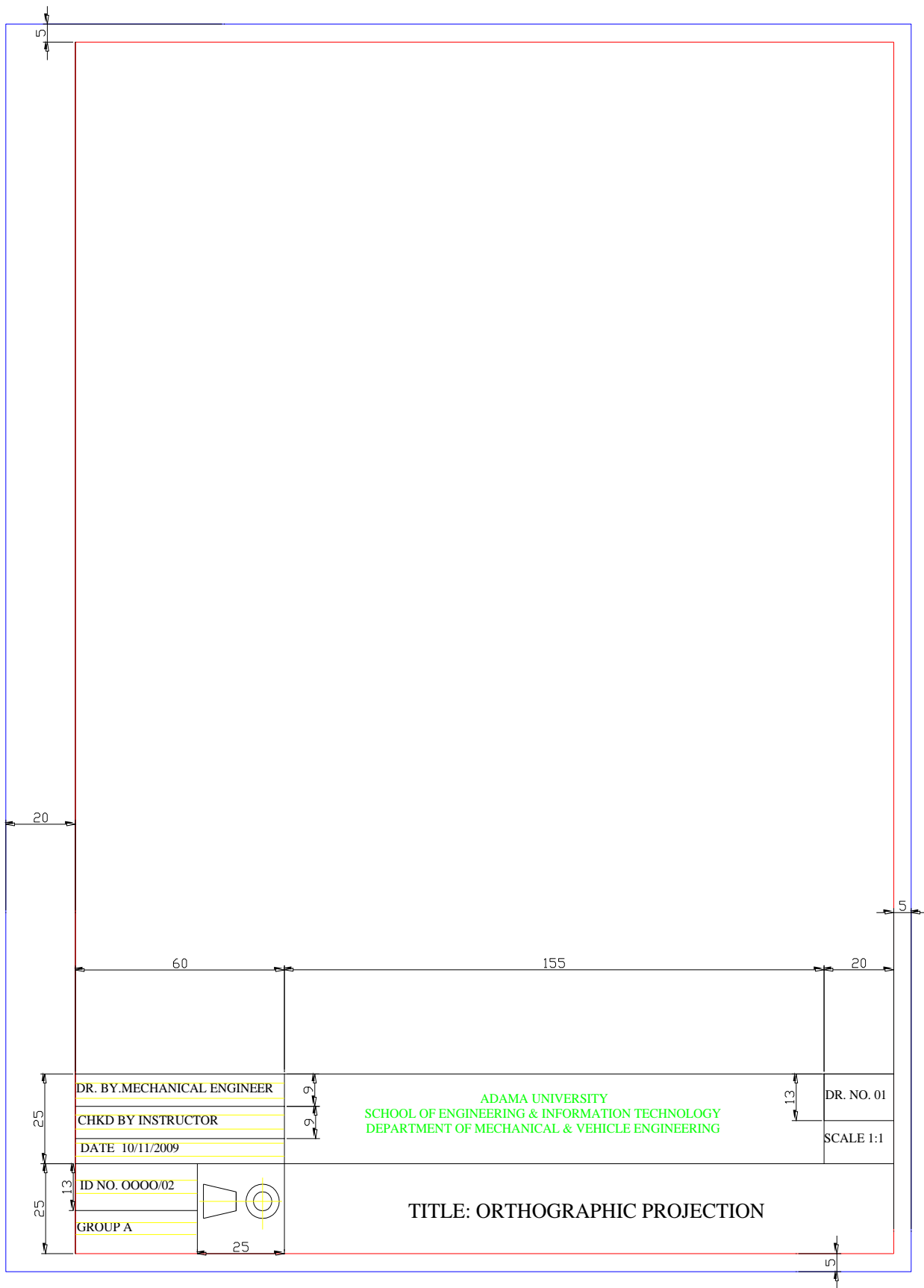
#### Sheet size

<i>Designation</i>	<i>Dimensions (mm)</i>
A0	841 × 1189
A1	594 × 841
A2	420 × 594
A3	297 × 420
A4	210 × 297

For this Module, we use 210mm X 297mm sized paper or A4 for the assignments or class works. We have the following elements to be noticed over the format of our drawing paper:

- **Border line:** it is the peripheral heaviest lines which enclose all drawings.
- **Title Block:** It is a box where all information about the drawing such as drawn by, checked by, date, scale, title of drawing, drawing number and company name are specified.
- **Guide line:** is the lightest line used to guide the height of alphabets.

#### Drawing Space:





- **Scale**

Scale is the ratio of the linear dimension of an element of an object as represented in the drawing, to the real linear dimension of the same element of the object itself. Wherever possible, it is desirable to make full size drawings, so as to represent true shapes and sizes. If this is not practicable, the largest possible scale should be used. While drawing very small objects, such as watch components and other similar objects, it is advisable to use enlarging scales.

**Designation and Recommendation of scale**

The complete designation of a scale should consist of the word Scale, followed by the indication of its ratio as:

SCALE 1 : 1 for full size,

SCALE  $\times$  : 1 for enlarged scales,

SCALE 1 :  $\times$  for reduced scales.

The designation of the scale used on the drawing should be shown in the title block.

**Table** Recommended scales

<i>Category</i>	<i>Recommended Scales</i>		
Enlarged scales	50:1	20:1	10:1
	5:1	2:1	
Full size			1:1
Reduced scales	1:2	1:5	1:10
	1:20	1:50	1:100
	1:200	1:500	1:1000
	1:2000	1:5000	1:10000

- **Lines**

Lines of different types and thicknesses are used for graphical representation of objects. The types of lines and their applications are shown in below.

<i>Line</i>	<i>Description</i>	<i>General Applications</i>
A	Continuous thick	A1 Visible outlines
B	Continuous thin (straight or curved)	B1 Imaginary lines of intersection B2 Dimension lines B3 Projection lines B4 Leader lines B5 Hatching lines B6 Outlines of revolved sections in place B7 Short centre lines
C	Continuous thin, free-hand	C1 Limits of partial or interrupted views and sections, if the limit is not a chain thin
D	Continuous thin (straight) with zigzags	D1 Line (see Fig. 2.5)
E	Dashed thick	E1 Hidden outlines
G	Chain thin	G1 Centre lines G2 Lines of symmetry G3 Trajectories
H	Chain thin, thick at ends and changes of direction	H1 Cutting planes
J	Chain thick	J1 Indication of lines or surfaces to which a special requirement applies
K	Chain thin, double-dashed	K1 Outlines of adjacent parts K2 Alternative and extreme positions of movable parts K3 Centroidal lines

- **Thickness of lines**

Two thicknesses of lines are used in draughting practice. The ratio of the thick to thin line should not be less than 2:1. The thickness of lines should be chosen according to the size and type of the drawing from the following range:

0.18, 0.25, 0.35, 0.5, 0.7, 1, 1.4 and 2

It is recommended that the space between two parallel lines, including hatching, should never be less than 0.7 mm.

A visible line takes precedence over all other lines



**0.70 mm**

Hidden lines and cutting plane lines take precedence over center lines

----- 0.35 mm

Center lines have lowest precedence

————— 0.35 mm

### 2.1.2. Tolerances and fits

When parts are assembled together, engineers have to decide ***how they will fit together*** and

the ***economics*** associated with it. The manufacture of interchangeable parts requires precision. Precision is the degree of accuracy to ensure the functioning of a part as intended.

- **Tolerance**

Tolerance is the difference between the maximum limit of size and the minimum limit of size.

The permissible variation of a size is called tolerance. It is the difference between the maximum and minimum permissible limits of the given size. If the variation is provided on one side of the basic size, it is termed as unilateral tolerance. Similarly, if the variation is provided on both sides of the basic size, it is known as bilateral tolerance.

- **Limit**

The two extreme permissible sizes between which the actual size is contained are called limits. The maximum size is called the upper limit and the minimum size is called the lower limit.

- **Deviation**

It is the algebraic difference between a size (actual, maximum, etc.) and the corresponding basic size.

- **Actual deviation**

It is the algebraic difference between the actual size and the corresponding basic size.

- **Upper deviation**

It is the algebraic difference between the maximum limit of the size and the corresponding basic size.

- **Lower deviation**

It is the algebraic difference between the minimum limit of the size and the corresponding basic size.

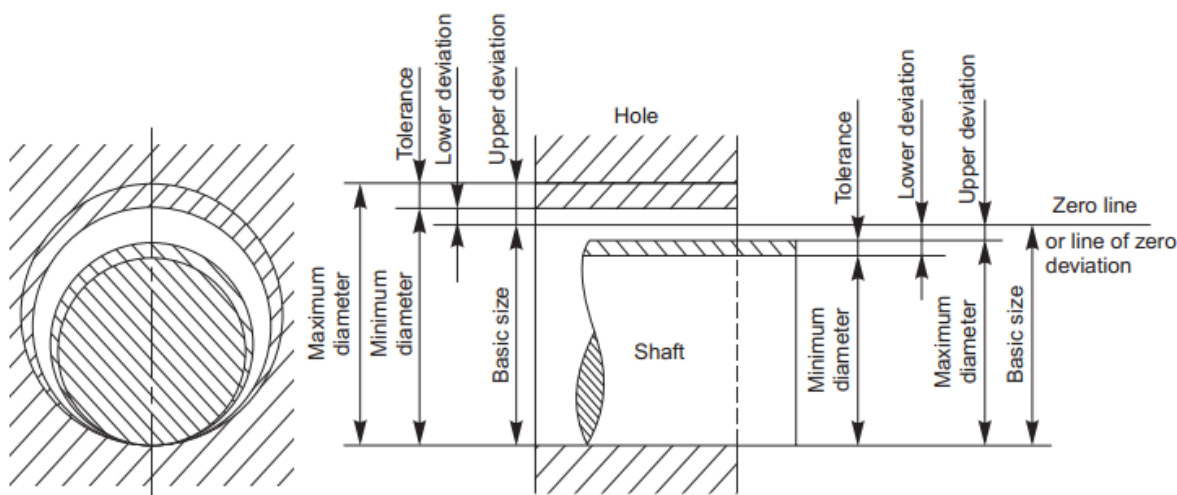
### **Allowance**

It is the dimensional difference between the maximum material limits of the mating parts, intentionally provided to obtain the desired class of fit. If the allowance is positive, it will result in minimum clearance between the mating parts and if the allowance is negative, it will result in maximum interference.

### **Basic Size**

It is determined solely from design calculations. If the strength and stiffness requirements need a 50mm diameter shaft, then 50mm is the basic shaft size. If it has to fit into a hole, then 50 mm is the basic size of the hole. Figure 15.1 illustrates the basic size, deviations and tolerances.

Here, the two limit dimensions of the shaft are deviating in the negative direction with respect to the basic size and those of the hole in the positive direction. The line corresponding to the basic size is called the zero line or line of zero deviation.



**Fig. .** Diagram illustrating basic size deviations and tolerances



### **Design Size**

It is that size, from which the limits of size are derived by the application of tolerances. If there is no allowance, the design size is the same as the basic size. If an allowance of 0.05 mm for clearance is applied, say to a shaft of 50 mm diameter, then its design size is  $(50 - 0.05) = 49.95$  mm. A tolerance is then applied to this dimension.

### **Actual Size**

It is the size obtained after manufacture.

### **Tolerance**

Great care and judgment must be exercised in deciding the tolerances which may be applied on various dimensions of a component. If tolerances are to be minimum, that is, if the accuracy requirements are severe, the cost of production increases. In fact, the actual specified tolerances dictate the method of manufacture. Hence, maximum possible tolerances must be recommended wherever possible

### **Bilateral tolerance**

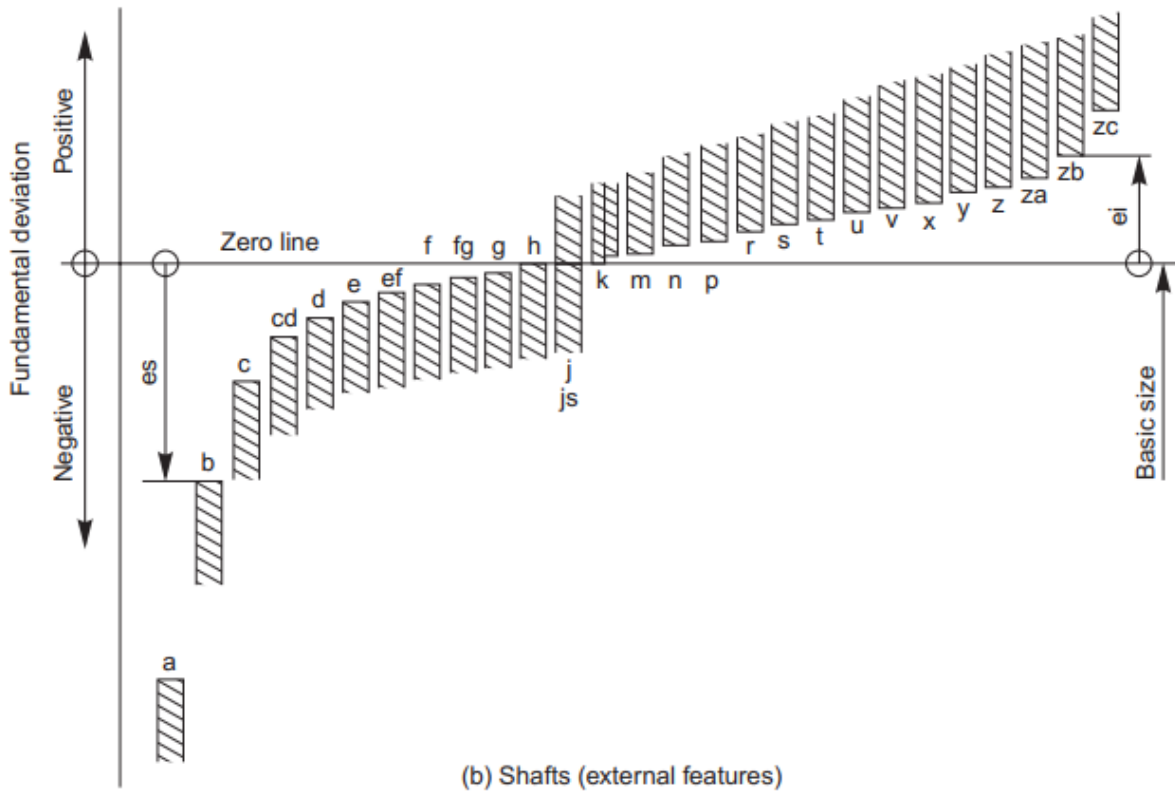
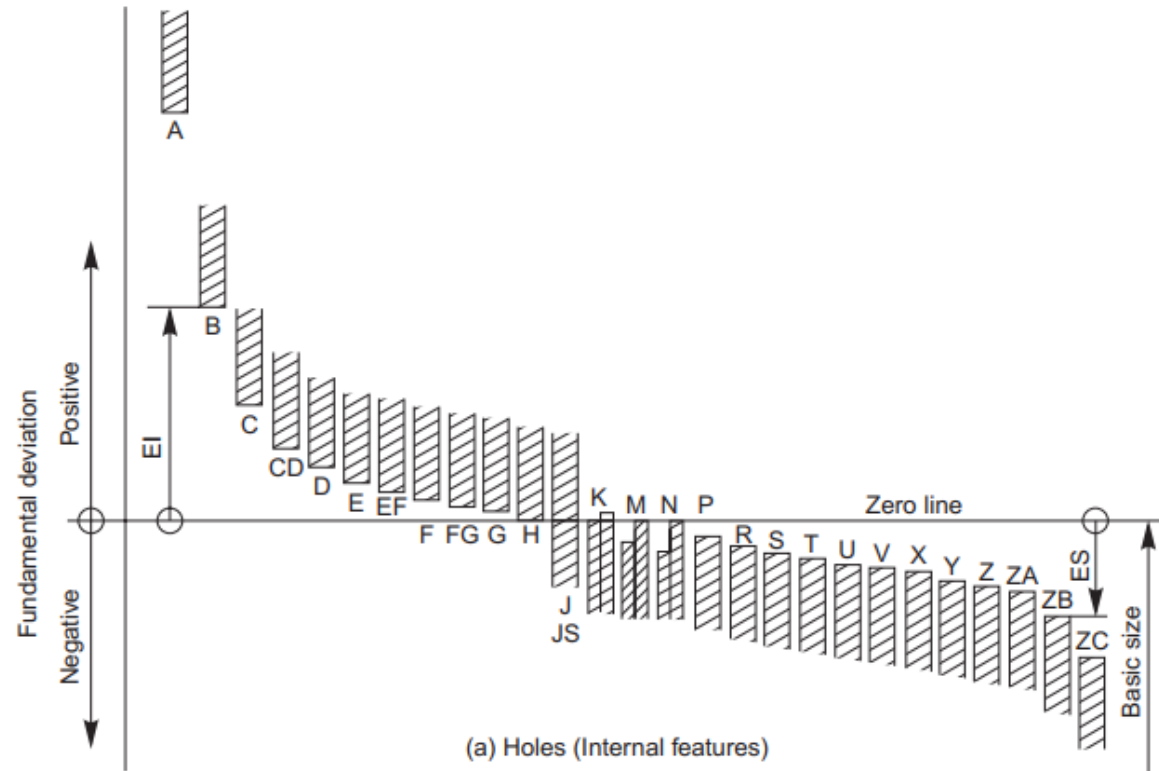
The variation in both directions from the basic dimension. That is, the basic size is between the two limits, for example,  $1.005 \pm 0.002$  in. The two parts of the tolerance need not be equal.

### **Unilateral tolerance**

The basic dimension is taken as one of the limits, and variation is permitted in only one direction, for example,

$$\begin{array}{l} +0.004 \\ 1.005 -0.000 \text{ in} \end{array}$$

Page 61 of 129	Federal TVET Agency Author/Copyright	Machining II Prepare Basic (2D) Engineering Drawing Using CAD	Version 1 October 2019
----------------	---	---	---------------------------

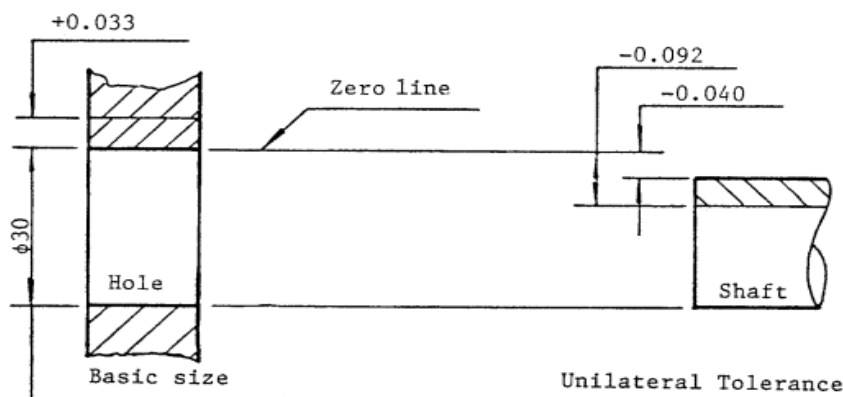


## Unilateral Tolerance

The upper and lower deviations are all positive or all negative.

$$\text{hole } \phi 30 \begin{matrix} +0.033 \\ 0 \end{matrix}$$

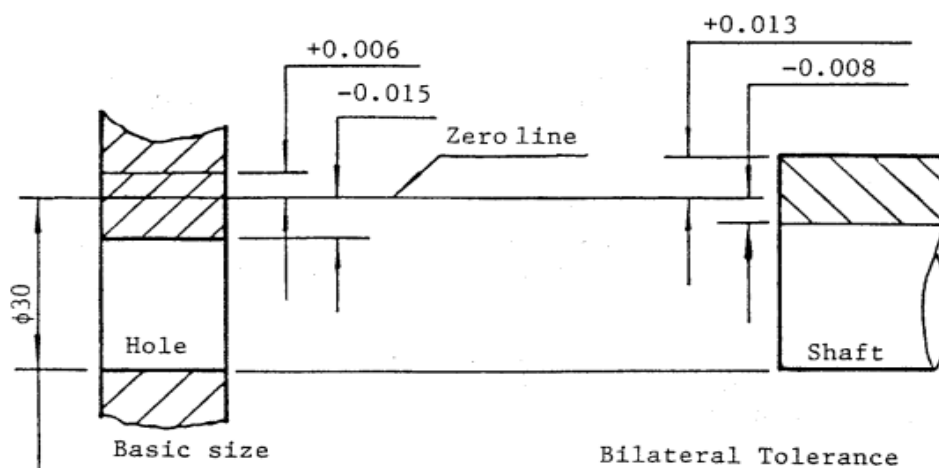
$$\text{shaft } \phi 30 \begin{matrix} -0.040 \\ -0.092 \end{matrix}$$



## Bilateral Tolerance

The tolerance is split above and below the basic size

$$\text{hole } \phi 30 \begin{matrix} +0.006 \\ -0.015 \end{matrix} \quad \text{shaft } \phi 30 \begin{matrix} +0.013 \\ -0.008 \end{matrix}$$



## Fit

The relation between two mating parts is known as a fit. Depending upon the actual limits of the hole or shaft sizes, fits may be classified as clearance fit, transition fit and interference fit.

### Clearance fit

It is a fit that gives a clearance between the two mating parts.

#### Minimum Clearance

It is the difference between the minimum size of the hole and the maximum size of the shaft in a clearance fit.

#### Maximum Clearance

It is the difference between the maximum size of the hole and the minimum size of the shaft in a clearance or transition fit. The fit between the shaft and hole in Fig. 15.10 is a clearance fit that permits a minimum clearance (allowance) value of  $29.95 - 29.90 = + 0.05$  mm and a maximum clearance of + 0.15 mm.

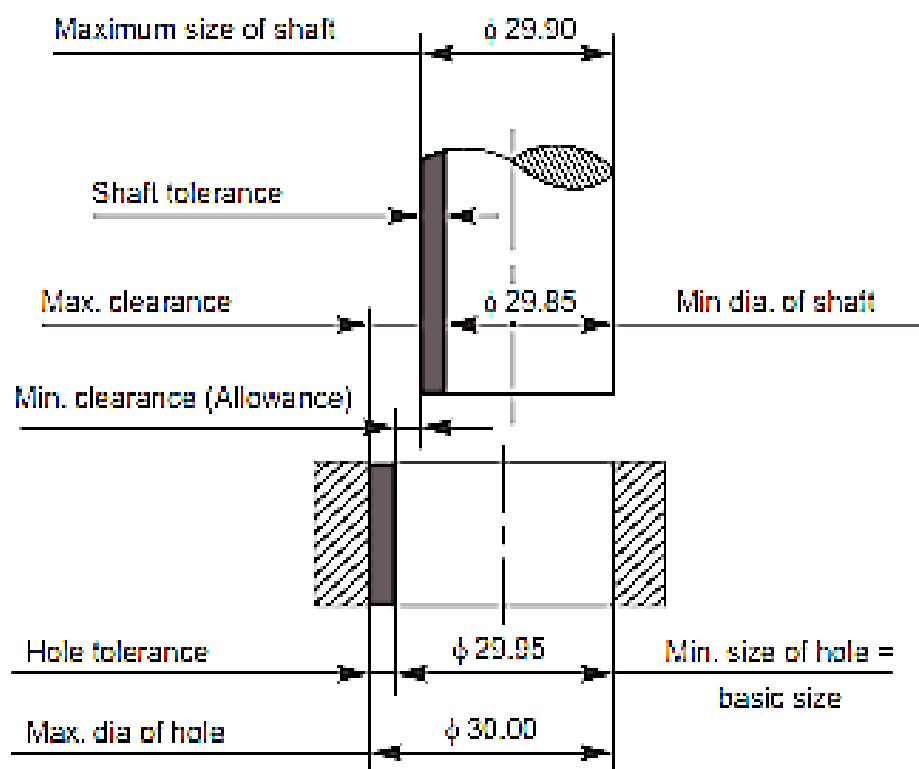


Fig. . Clearance fit



## Transition fit

This fit may result in either interference or a clearance, depending upon the actual values of the tolerance of individual parts. The shaft in Fig. 15.11 may be either smaller or larger than the hole and still be within the prescribed tolerances. It results in a clearance fit, when shaft diameter is 29.95 and hole diameter is 30.05 (+ 0.10 mm) and interference fit, when shaft diameter is 30.00 and hole diameter 29.95 (– 0.05 mm).

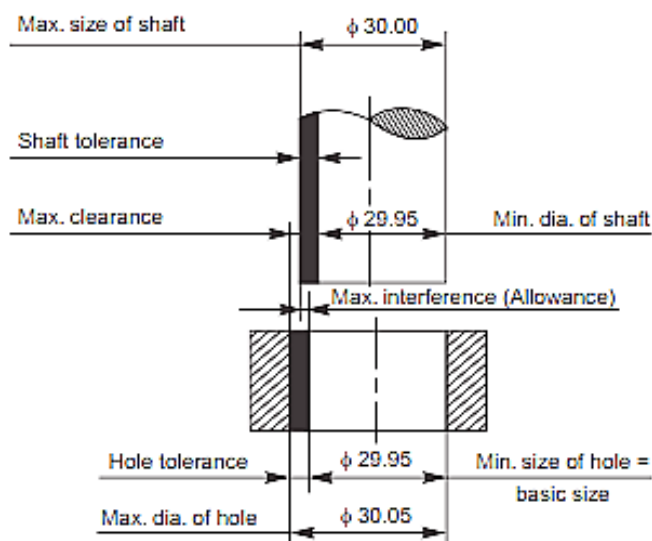


Fig. Transition fit

## Interference fit

If the difference between the hole and shaft sizes is negative before assembly; an interference fit is obtained.

### Minimum Interference

It is the magnitude of the difference (negative) between the maximum size of the hole and the minimum size of the shaft in an interference fit before assembly.

### Maximum Interference

It is the magnitude of the difference between the minimum size of the hole and the maximum size of the shaft in interference or a transition fit before assembly. The shaft in Fig. 15.12 is larger than the hole, so it requires a press fit, which has an effect similar to welding of two parts.

The value of minimum interference is  $30.25 - 30.30 = -0.05$  mm and maximum interference is  $30.15 - 30.40 = -0.25$  mm.

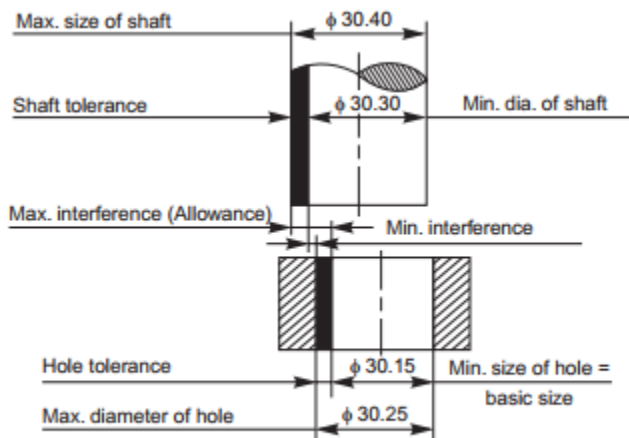


Fig. 1 Interference fit

Figure 1 shows the conventional representation of these three classes of fits.

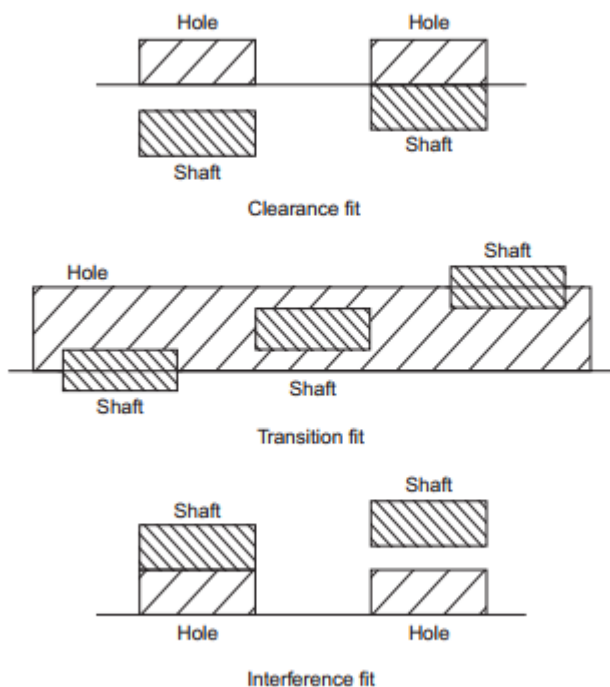


Fig. Schematic representation of fits

### 2.1.3. Isometric, orthographic and exploded view drafting

#### Pictorial drawing

##### Definition:

It is a three dimensional representation of an object.

#### COMPARISON OF MULTI VIEW DRAWING AND PICTORIAL DRAWING

Pictorial drawings have the following features to multi view drawing:

- Is an effective means of communicating an idea
- Shows only the appearances of parts and designs
- Extensively used in catalogs of sales, manufacture, maintenance publications, ...
- Show several sides over a single view
- Not satisfactory for complete description of an object

#### TYPES OF PICTORIAL DRAWING:

The most common types are three. These are:

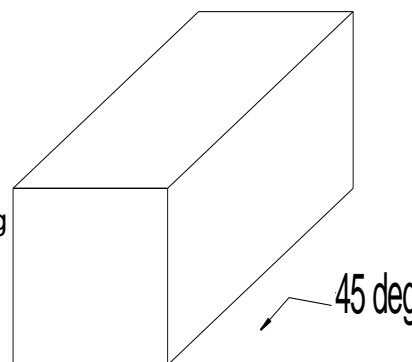
1. Oblique
2. Axonometric – Isometric
3. Perspective

##### 1. OBLIQUE DRAWING:

It is easiest of the three to draw. But seldom used.

Front view is drawn exactly as it would appear in multi view drawing

- ✓ Circles appear as a true circle over the front view.
- ✓ Rectangles parallel to the frontal plane are in true size



You use 3-axes; two at right angles and one at an angle of convenient,

but most of the time it is preferable to use 45°.

The line of sight should not make an angle less than  $45^\circ$  with the picture plane. This would result in a receding axis longer than true length, thereby distorting the pictorial.

Advantage:

- Circles or cylinders can easily drawn easily on the front face in their true shape
- Irregular shapes can be easily sketched on the front view in the same manner.

## 2. AXONOMETRIC DRAWINGS

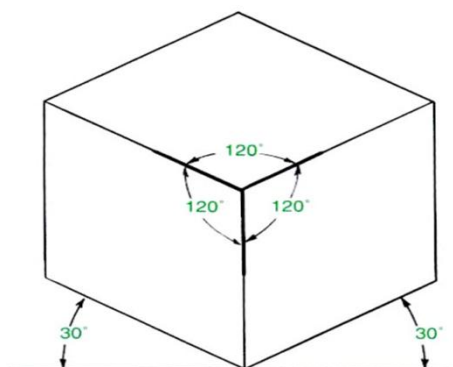
In axonometric drawing the three faces of rectangular object are all inclined to the plane of projection. Here the observer is considered to be at infinity, and the visual rays are parallel to each other and perpendicular to the plane of projection.

By chapter one, we have already considered the three types of axonometric projections. These are:

- A. Isometric drawing
- B. Diametric drawing
- C. Trimetric drawing

### A. Isometric drawing

- Isometric means *equal measure*.
- Makes equal angle with the principal plane ( $120^\circ$ ).
- Is the most commonly used axonometric drawing type.



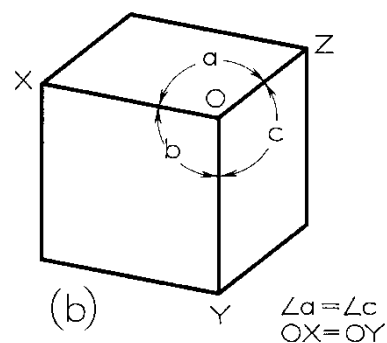
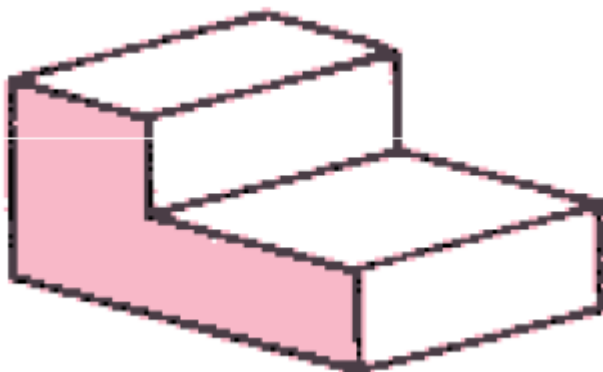
### Notice:

\* Isometric drawing is similar to an Isometric projection except that it is not a true axonometric projection, but an approximate method of drawing a pictorial.

\*\* Isometric projection is foreshortened by 82% of full size. The Isometric drawing is drawn full size for convenience.

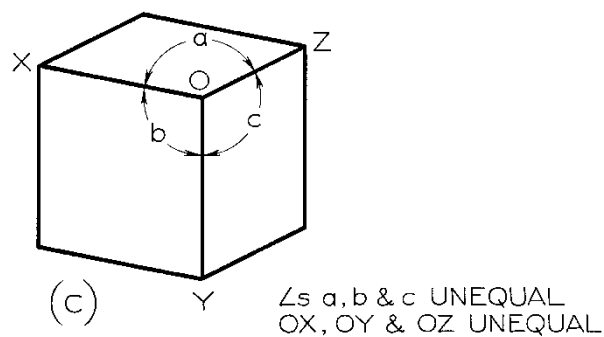
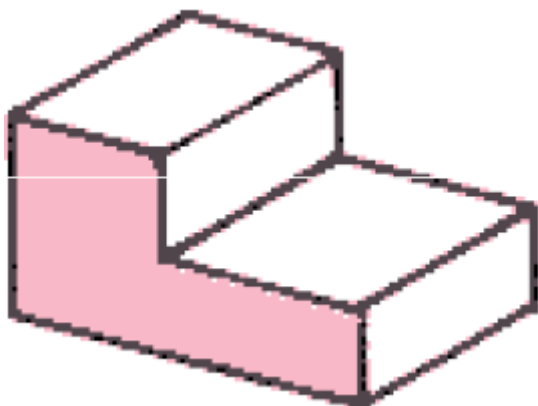
### B. Diametric drawing

- Two principal planes have equal angle measurement.
- seldom used

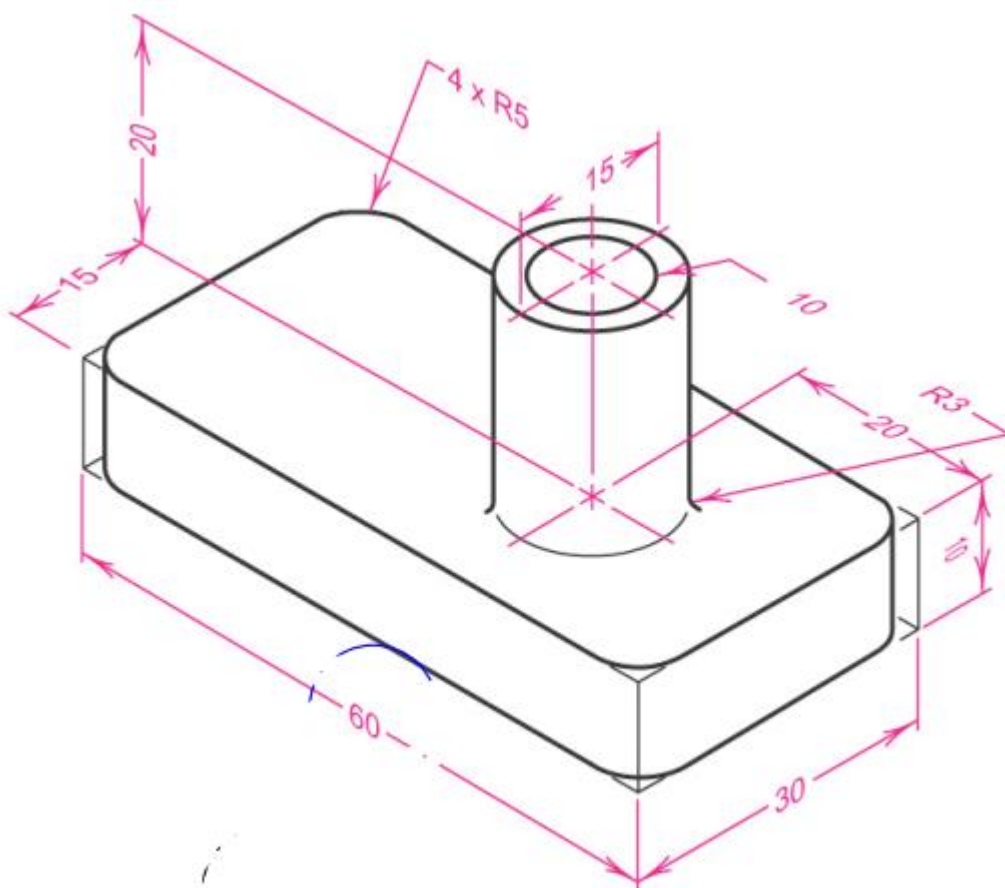


### C. Trimetric drawing

- All angles measured in principal planes are none equal.



Redraw isometric drawing



### 3. PERSPECTIVE DRAWING

- Central projection is the other calling name.

It excels over all other types of projection in the pictorial representation of objects because it more closely approximates the view obtained by the human eye.

Terminology:

- The station of the observer's eye is called *Station point (SP)*.
- The imaginary plane of projection is called *Picture plane (PP)*.
- The point where all projection lines converge is called *vanishing point (VP)*.
- A horizontal line in the front view representing an infinite horizontal is called *Horizon*.




The *three* basic types of perspectives are:

- I. One point – single vanishing point
- II. Two point – two vanishing point
- III. Three point – three vanishing point

### **ONE POINT PERSPECTIVE DRAWING**

Has one surface of the object parallel to the picture plane. However, other sides vanish to a single point. To draw one point perspective projection, we can develop from top and front views of an object.

-  When drawing any perspective, the station point should be placed far enough away from the object to permit the cone of vision to be less than  $30^\circ$  to reduce distortion.

We can work one point perspective either by simply selecting a stationary point or by measuring points. The use of measuring point eliminates the need of placing top view above the front view.

### **MULTIVIEW DRAWING**

Multi view projection is a method by which the exact shape of an object can be represented by two or more separate views produced on projection planes that are at right angles to each other.

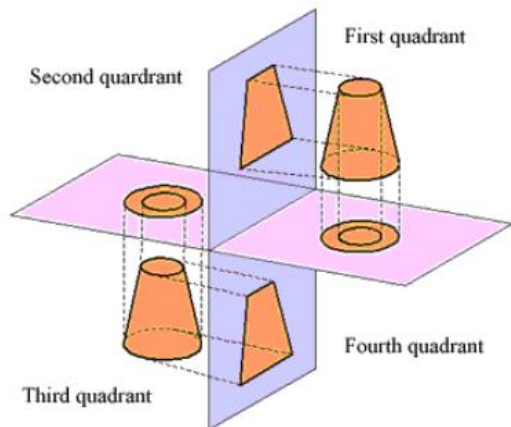
The system of constructing multi view drawing is orthographic projection. Orthographic views are two dimensional views of three dimensional objects.

### **SYSTEM OF PROJECTIONS**

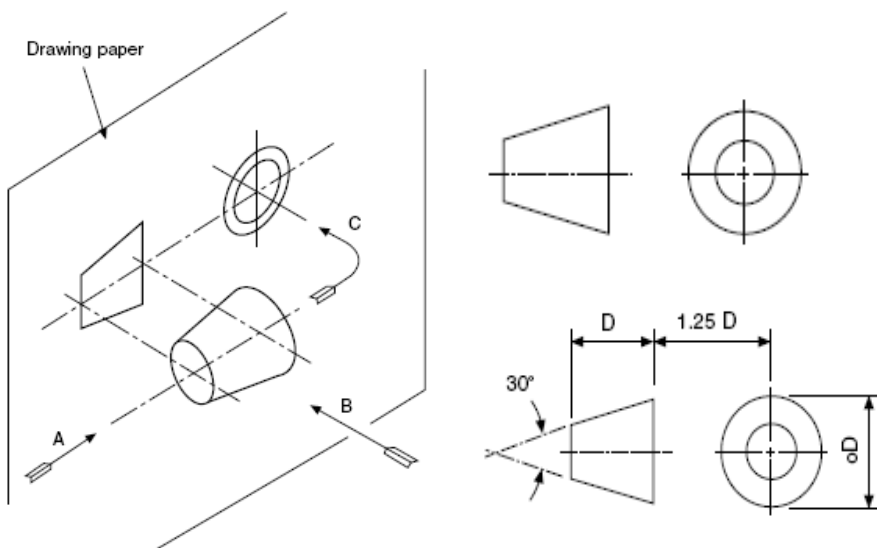
There are two types of projection systems in use today. These are:

- ➡ *Third-angle projection* is used in the United States, Canada, and in many other countries.
- ➡ *First-angle projection* is used mainly in Europe.

Page 71 of 129	Federal TVET Agency Author/Copyright	Machining II Prepare Basic (2D) Engineering Drawing Using CAD	Version 1 October 2019
----------------	---	---	---------------------------

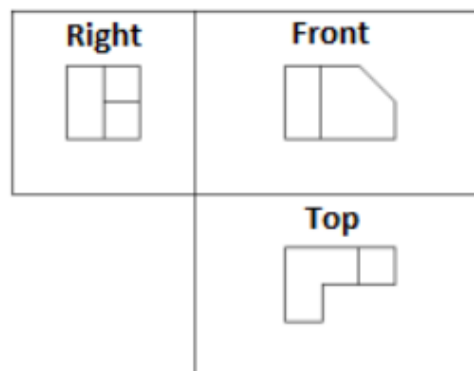
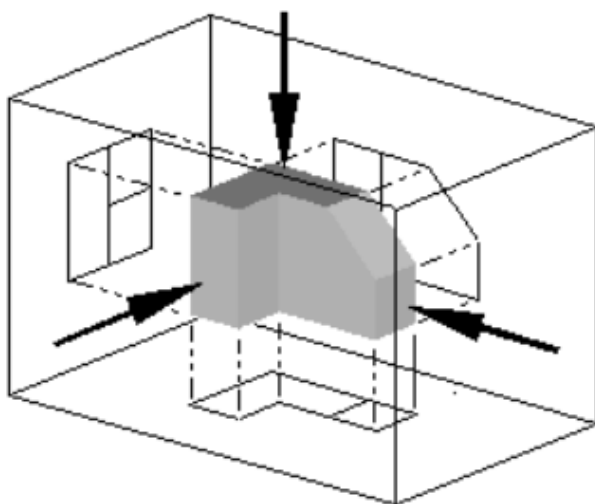
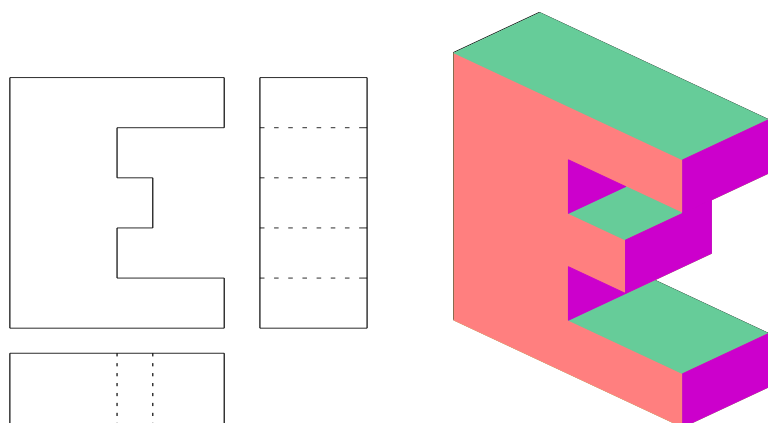


Symbolic representation of first angle orthographic projection is:

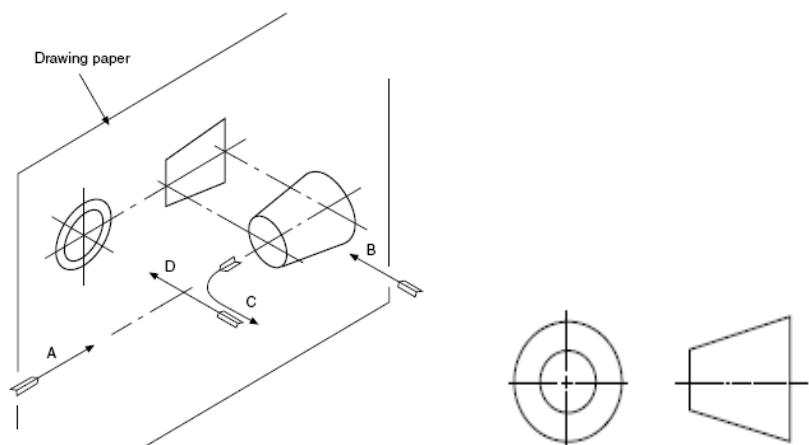




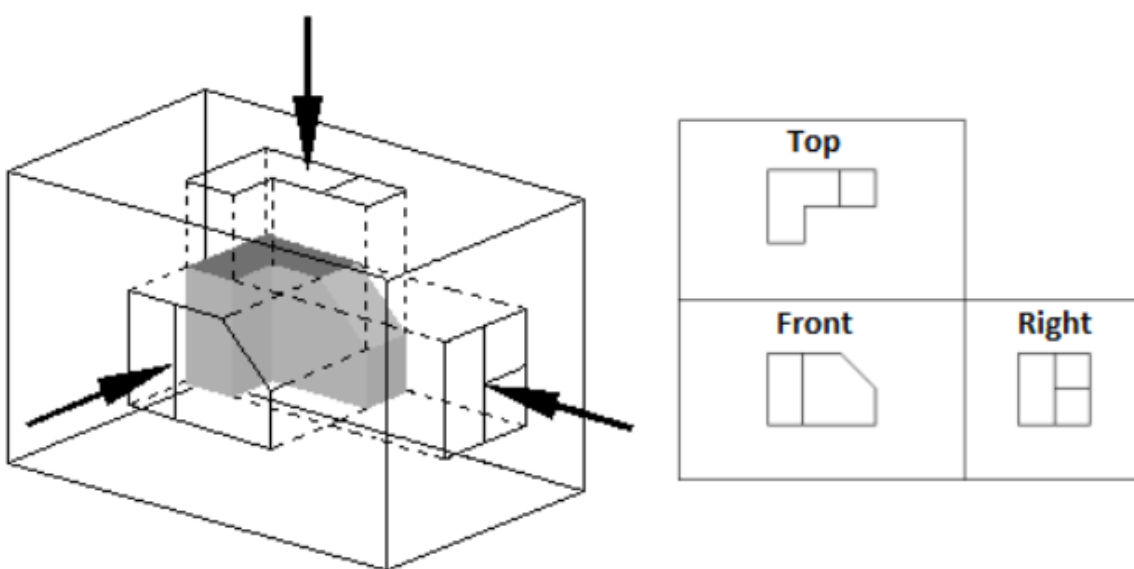
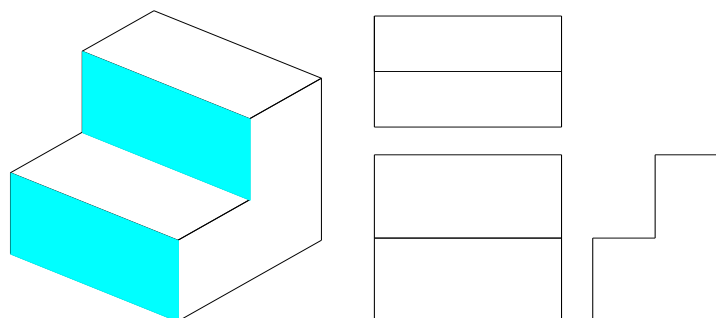
Example:



The standard symbolic representation for the third angle projection is:



Examples:



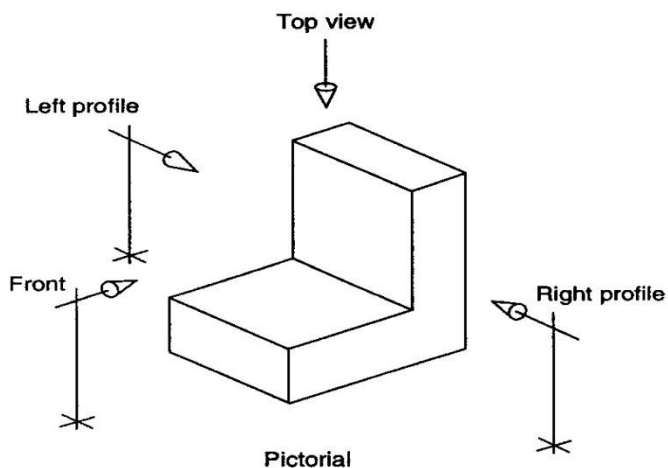
## Comparisons

FIRST ANGLE PROJECTION	THIRD ANGLE PROJECTION
<div style="display: flex; justify-content: space-around; margin-bottom: 20px;"> <div style="border: 1px solid #007bff; border-radius: 10px; padding: 5px 15px;">R.S.V</div> <div style="border: 1px solid #007bff; border-radius: 10px; padding: 5px 15px;">F.V</div> <div style="border: 1px solid #007bff; border-radius: 10px; padding: 5px 15px;">L.S.V</div> </div> <div style="border: 1px solid #007bff; border-radius: 10px; padding: 5px 15px; margin: 0 auto;">T.V</div>	<div style="border: 1px solid #007bff; border-radius: 10px; padding: 5px 15px; margin: 0 auto 20px auto;">T.V</div> <div style="display: flex; justify-content: space-around; margin-top: 20px;"> <div style="border: 1px solid #007bff; border-radius: 10px; padding: 5px 15px;">L.S.V</div> <div style="border: 1px solid #007bff; border-radius: 10px; padding: 5px 15px;">F.V</div> <div style="border: 1px solid #007bff; border-radius: 10px; padding: 5px 15px;">R.S.V</div> </div>

### Orthographic projection:

- ✓ Is a system of views of an object formed by projectors from the object perpendicular to the desired planes of projection.
- ✓ Here we have three principal projection planes. That is to say:
  - Horizontal projection plane (H)
  - Frontal projection plane (F)
  - Profile projection plane (P)

For example:



For the above object we can have orthographic projection as follow:

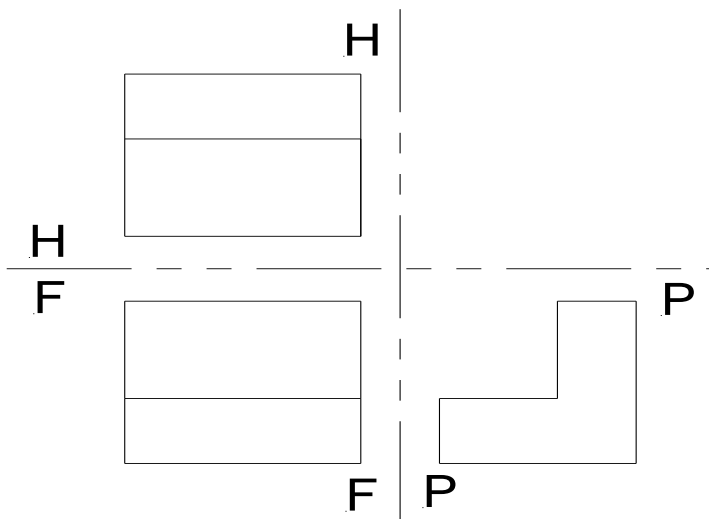


Fig. Orthographic projection (Multi-view drawing)

### Choice & layout of views

Six principal views can be obtained for any object by using the principles of multi view drawing or orthographic projection which are the maximum views. Width dimension remains the same



for top, front and bottom views. Whereas height is common for right side, front, left-side, and rear views.

Only views that are necessary for a clear and complete description should be selected. Because the repetition of information may tends to confuse the reader. So that, it is important to have a set of views that describe an object clearly.

Technical drawings usually include only the front, top and right side orthographic views because together they are considered sufficient to completely define an object's shape.

#### GROUND RULES FOR SELECTION OF VIEWS

- Right hand side view should be used in preference to a left side view and a top view in preference to a bottom view.
- Place the object to obtain the smallest number of hidden lines. When both views of an equal numbers of hidden lines exist, the right side view will be traditionally selected.

#### PRESEDNCE OF LINES

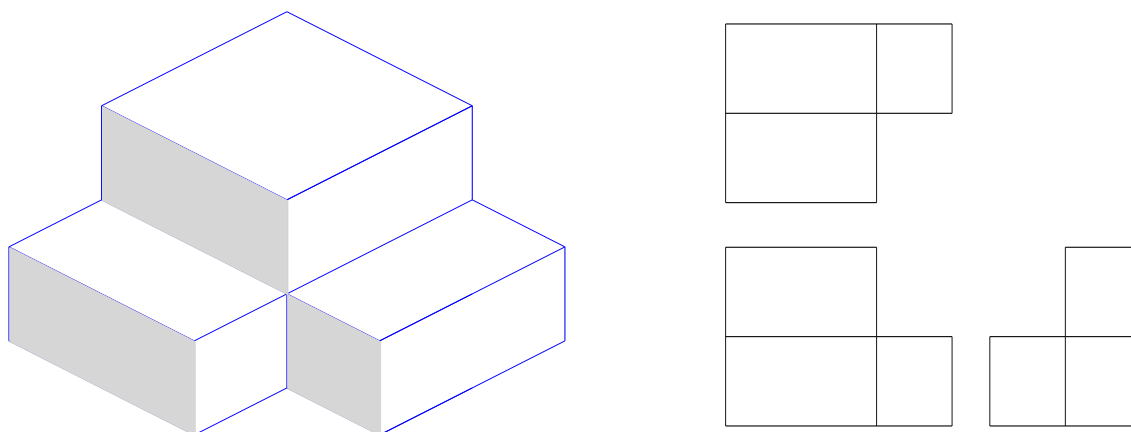
The following listed lines are the various types conventionally used over the world now a day;

- Visible Lines – solid thick lines that represent visible edges or contours
- Hidden Lines – short evenly spaced dashes that depict hidden features
- Section Lines – solid thin lines that indicate cut surfaces
- Center Lines – alternating long and short dashes
- Dimensioning
  - Dimension Lines - solid thin lines showing dimension extent/direction
  - Extension Lines - solid thin lines showing point or line to which dimension applies
  - Leaders – direct notes, dimensions, symbols, part numbers, etc. to features on drawing
- Cutting-Plane and Viewing-Plane Lines – indicate location of cutting planes for sectional views and the viewing position for removed partial views
- Break Lines – indicate only portion of object is drawn. May be random “squiggled” line or thin dashes joined by zigzags.
- Phantom Lines – long thin dashes separated by pairs of short dashes indicate alternate positions of moving parts, adjacent position of related parts and repeated detail
- Chain Line – Lines or surfaces with special requirements

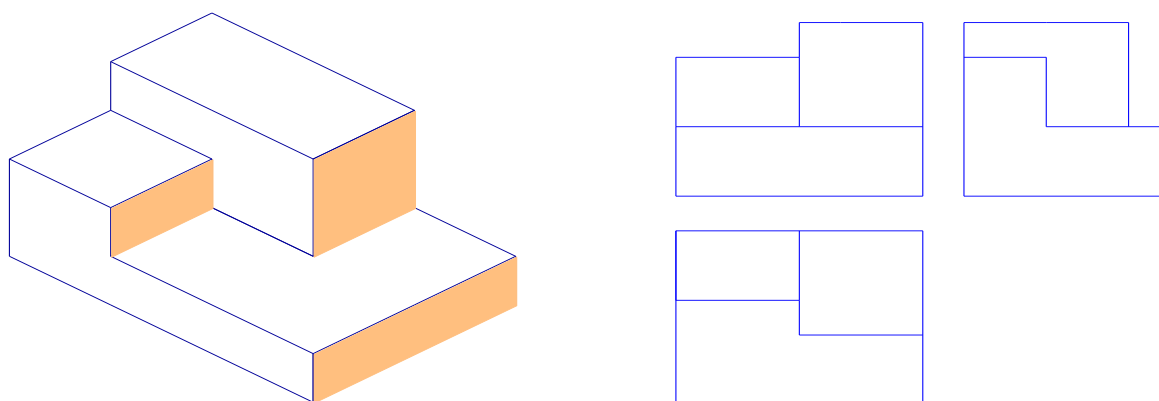
Page 77 of 129	Federal TVET Agency Author/Copyright	Machining II Prepare Basic (2D) Engineering Drawing Using CAD	Version 1 October 2019
----------------	---	---	---------------------------

### Exercise

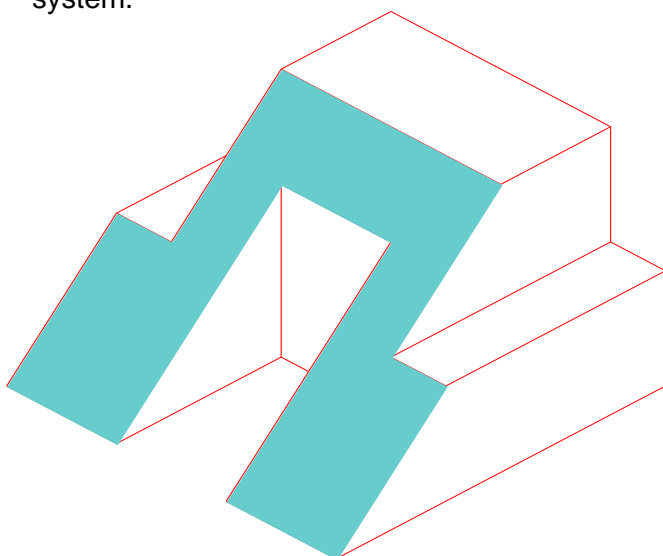
1. Orthographic projection of a box using third angle projection system:



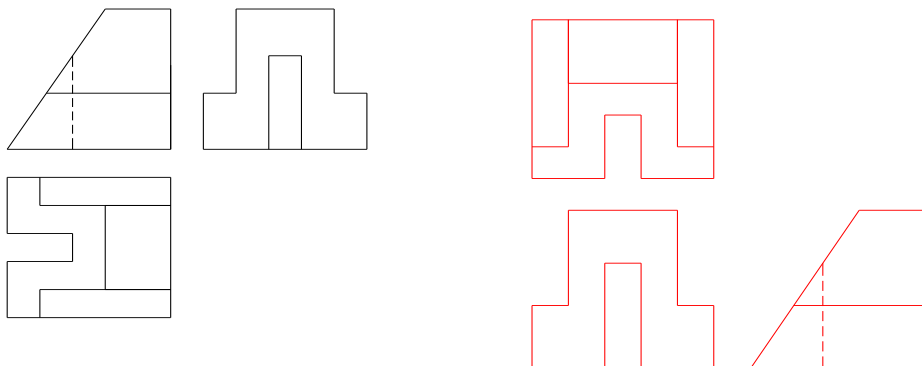
2. Orthographic projection for an object using first angle projection system:



3. Draw the multi view drawing of the following object with both 1<sup>st</sup> and 3<sup>rd</sup> angle projection system.



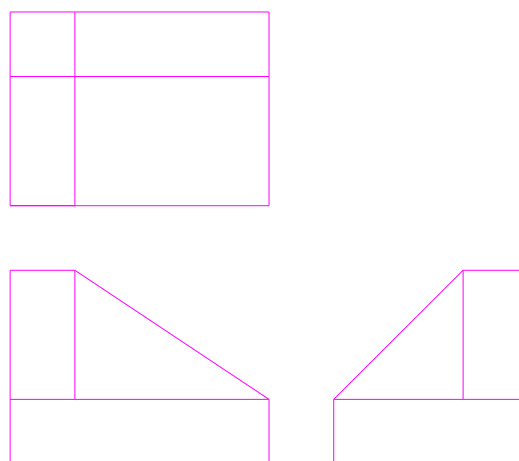
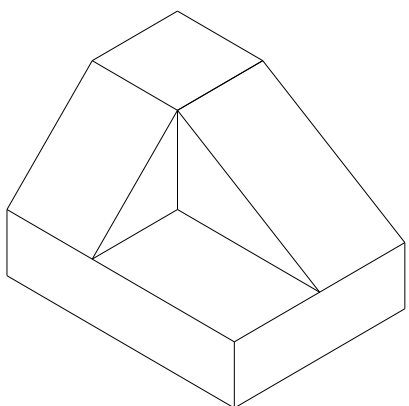
Orthographic projection of the above object was given below with both projection systems.



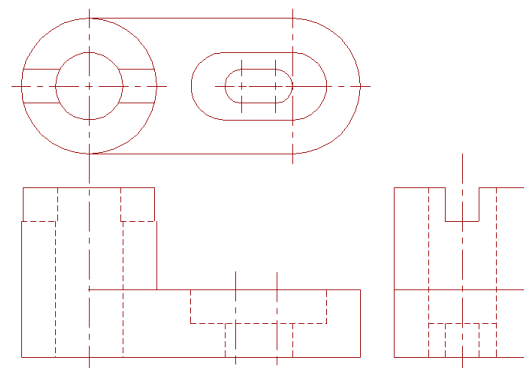
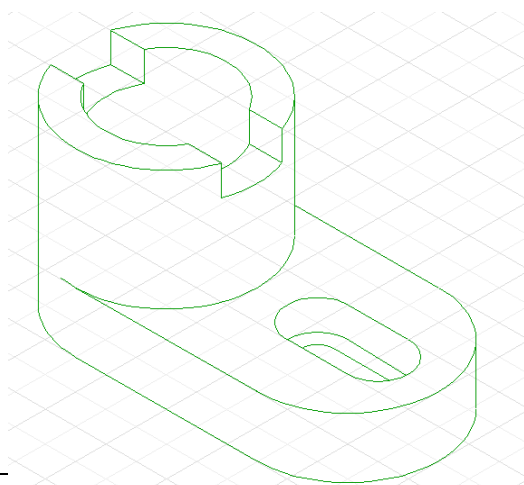
a. First angle projection system

b. Third angle projection system

4. Draw orthographic projection of the following object using third angle projection system.



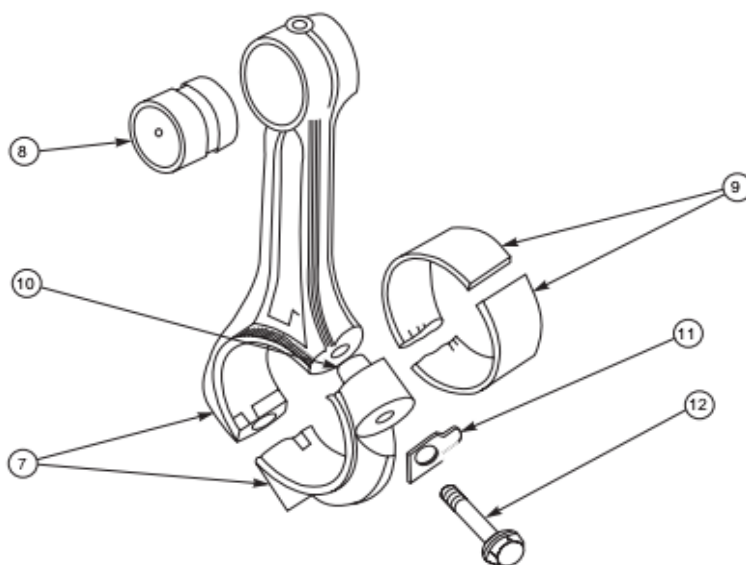
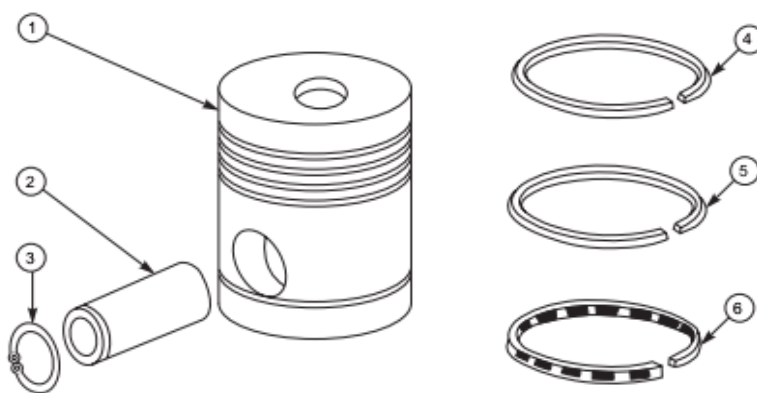
5. Draw orthographic view of the following object using third angle projection system:



<https://www.youtube.com/watch?v=c6DyqJMwos8>

### Explode view

In some cases, exploded pictorial views are supplied to meet instruction manual requirements. These drawings generally find a place in the parts list section of a company instruction manual. Figure below shows drawings of this type which may be easily understood even by those with less experience in the reading of drawings; because in these exploded views, the parts are positioned in the sequence of assembly, but separated from each other.



Exploded assembly drawing

<https://www.youtube.com/watch?v=5EmmalML8xM>





<b>Self-Check -1</b>	<b>Written Test</b>
----------------------	---------------------

**Directions:** Answer all the questions listed below. Use the Answer sheet provided in the next page:

**Say true and false.**

1. Allowance is the dimensional difference between the maximum material limits of the mating parts.
2. Tolerance is the permissible variation of a size.
3. Fit is the relation between two mating parts.
4. Orthographic views are two dimensional views.

**Note: Satisfactory rating - 2 and 4 points      Unsatisfactory - below 2 and 4 points**

You can ask you teacher for the copy of the correct answers.

Page 81 of 129	Federal TVET Agency Author/Copyright	Machining II Prepare Basic (2D) Engineering Drawing Using CAD	Version 1 October 2019
----------------	---	---	---------------------------



## Answer Sheet

Score = \_\_\_\_\_

Rating: \_\_\_\_\_

Name: \_\_\_\_\_

Date: \_\_\_\_\_

### Short Answer Questions

- 1.
- 2.
- 3.
- 4.



<b>Information Sheet-2</b>	<b>Indicating dimensions, notes and specifications</b>
----------------------------	--

## 2.1. Dimension

A drawing of a component, in addition to providing complete shape description, must also furnish information regarding the size description. These are provided through the distances between the surfaces, location of holes, nature of surface finish, type of material, etc. The expression of these features on a drawing, using lines, symbols, figures and notes is called dimensioning.

### General principle

Dimension is a numerical value expressed in appropriate units of measurement and indicated on drawings, using lines, symbols, notes, etc., so that all features are completely defined.

1. As far as possible, dimensions should be placed outside the view.
2. Dimensions should be taken from visible outlines rather than from hidden lines.
3. Dimensioning to a center line should be avoided except when the centre line passes through the center of a hole.
4. Each feature should be dimensioned once only on a drawing.
5. Dimensions should be placed on the view or section that relates most clearly to the corresponding features.
6. Each drawing should use the same unit for all dimensions, but without showing the unit symbol.
7. No more dimensions than are necessary to define a part should be shown on a drawing.
8. No features of a part should be defined by more than one dimension in any one direction

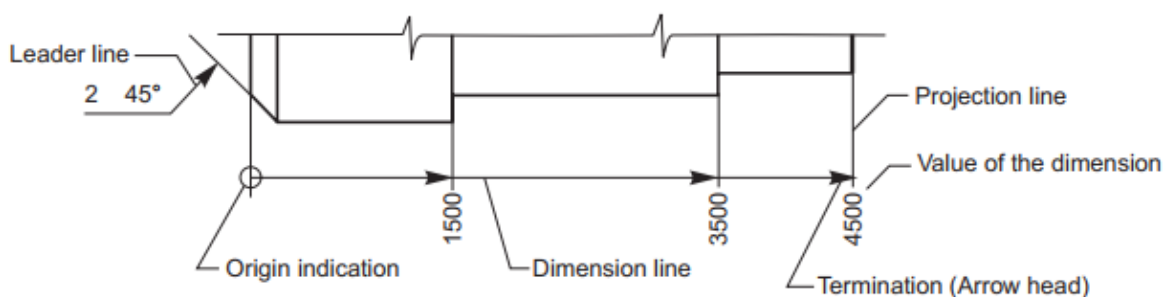
### Method of execution

The elements of dimensioning include the projection line, dimension line, leader line, dimension

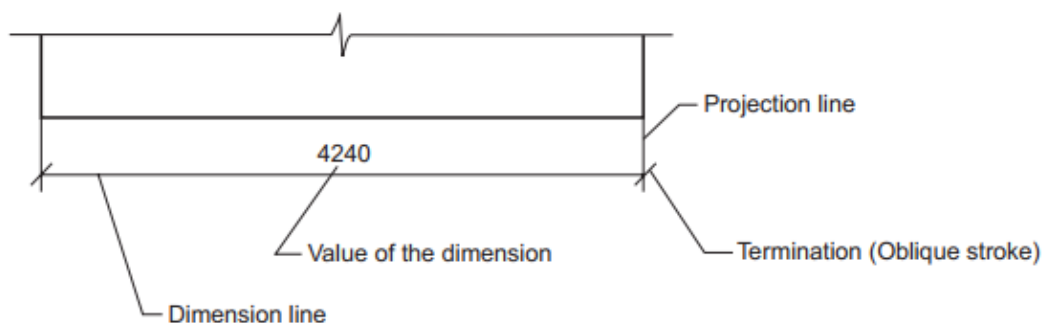
line termination, the origin indication and the dimension itself. The various elements of

Page 83 of 129	Federal TVET Agency Author/Copyright	Machining II Prepare Basic (2D) Engineering Drawing Using CAD	Version 1 October 2019
----------------	---	---	---------------------------

dimensioning are shown in Figs. 2.28 and 2.29. The following are some of the principles to be adopted during execution of dimensioning:

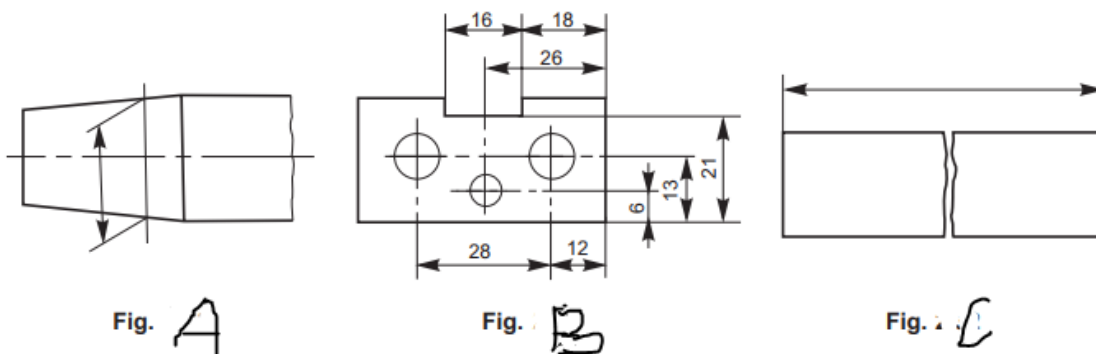


**Fig.** Elements of dimensioning



**Fig.**

1. Projection and dimension lines should be drawn as thin continuous lines.
2. Projection lines should extend slightly beyond the respective dimension lines.
3. Projection lines should be drawn perpendicular to the feature being dimensioned. Where necessary, they may be drawn obliquely, but parallel to each other (Fig. 2.30A). However, they must be in contact with the feature.
4. Projection lines and dimension lines should not cross each other, unless it is unavoidable (Fig. 2.31B).
5. A dimension line should be shown unbroken, even where the feature to which it refers, is shown broken (Fig. 2.32C).
6. A centre line or the outline of a part should not be used as a dimension line, but may be used in place of projection line (Fig. 2.31A).



### Methods of indicating dimension

Dimensions should be shown on drawings in characters of sufficient size, to ensure complete legibility. They should be placed in such a way that they are not crossed or separated by any other line on the drawing. Dimensions should be indicated on a drawing, according to one of the following two methods. However, only one method should be used on any one drawing.

#### METHOD-1 (Aligned System)

Dimensions should be placed parallel to their dimension lines and preferably near the middle, above and clear-off the dimension line (Fig. 2.36). An exception may be made where superimposed running dimensions are used (Fig. 2.44 b)

Dimensions may be written so that they can be read from the bottom or from the right side of the drawing. Dimensions on oblique dimension lines should be oriented as shown in Fig. 2.37. Angular dimensions may be oriented as shown in Fig. 2.38.

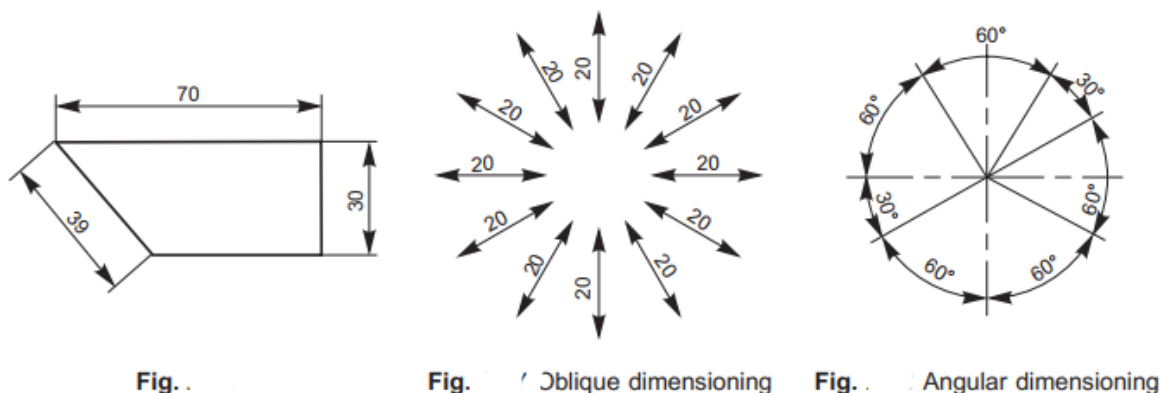


Fig. .

Fig. . Oblique dimensioning

Fig. . Angular dimensioning

## METHOD-2 (Uni-directional System)

Dimensions should be indicated so that they can be read from the bottom of the drawing only. Non-horizontal dimension lines are interrupted, preferably near the middle, for insertion of the dimension (Fig. 2.39).

Angular dimensions may be oriented as in Fig. 2.40.

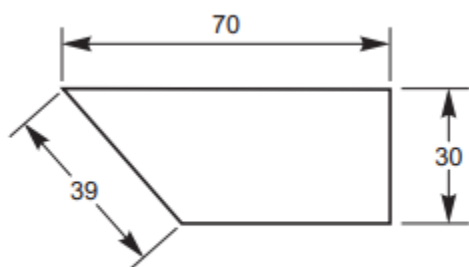


Fig. 2.39

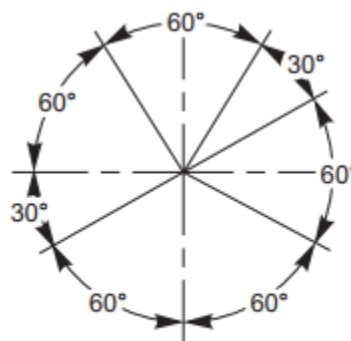
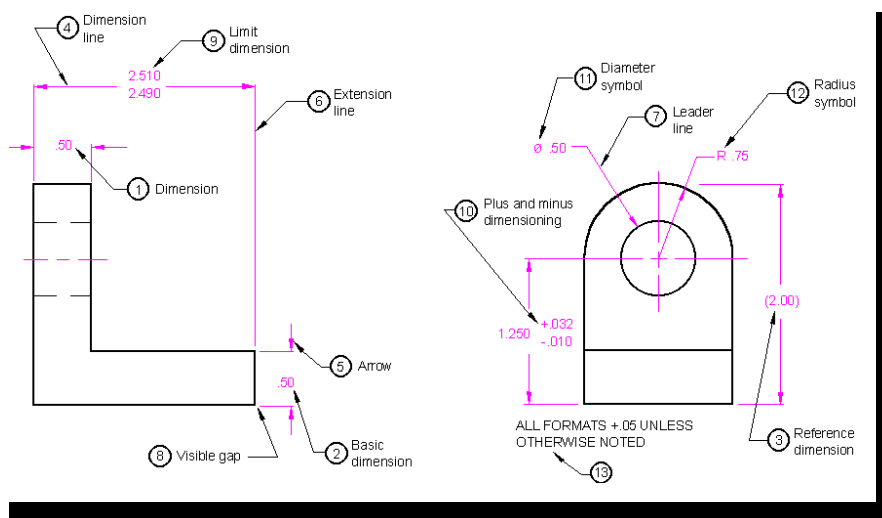


Fig. 2.40 Angular dimensioning

Dimensions can be, (i) above the extension of the dimension line, beyond one of the terminations, where space is limited (Fig. 2.34) or (ii) at the end of a leader line, which terminates on a dimension line, that is too short to permit normal dimension placement (Fig. 2.34) or (iii) above a horizontal extension of a dimension line, where space does not allow placement at the interruption of a non-horizontal dimension line (Fig. 2.41).

Values of dimensions, out of scale (except where break lines are used) should be underlined as shown in Fig. 2.41



## Arrangement of dimensions

The arrangement of dimensions on a drawing must indicate clearly the design purpose.

The following are the ways of arranging the dimensions.

### Chain dimensions

Chains of single dimensions should be used only where the possible accumulation of tolerances does not endanger the functional requirement of the part (Fig. 2.43).

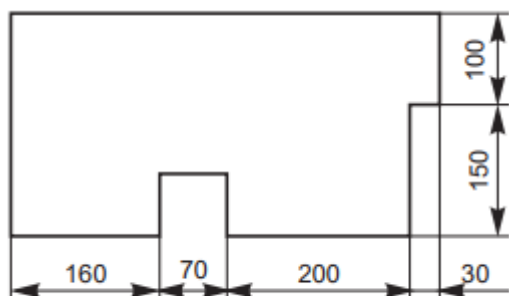
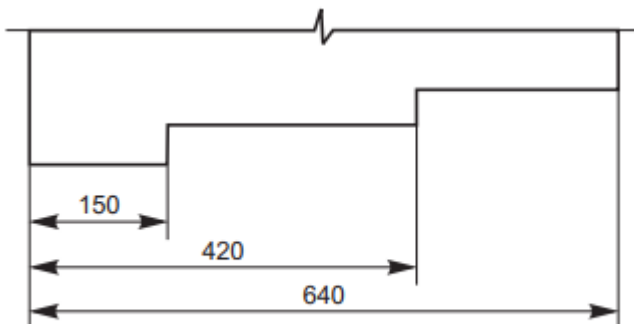


Fig. 2.43 Chain dimensioning

### Parallel dimensions

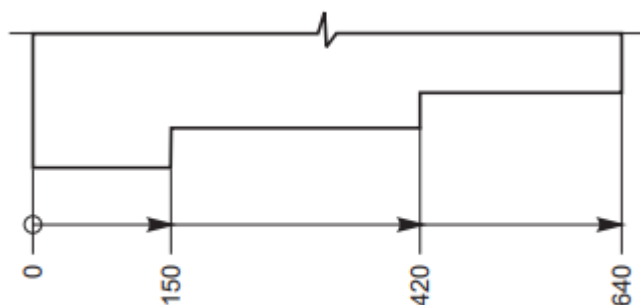
In parallel dimensioning, a number of dimension lines, parallel to one another and spaced-out are used. This method is used where a number of dimensions have a common datum feature (Fig. 2.44 a).



(a)

### Super imposed Running dimensions

These are simplified parallel dimensions and may be used where there are space limitations (Fig. 2.44 b).



(b)

### Combined dimension

These are the result of simultaneous use of chain and parallel dimensions (Fig. 2.45).

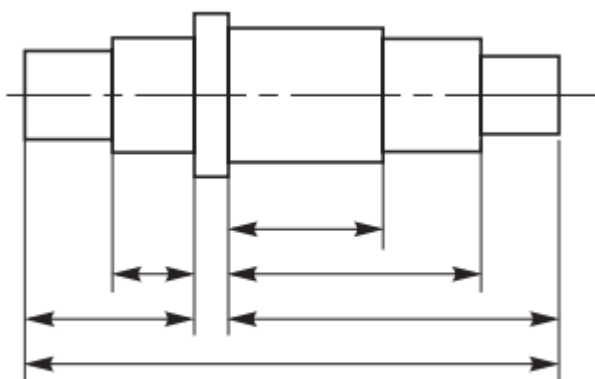


Fig. Combined dimensioning

### Co-ordinate dimension

The sizes of the holes and their co-ordinates may be indicated directly on the drawing; or they may be conveniently presented in a tabular form, as shown in Fig. 2.46.

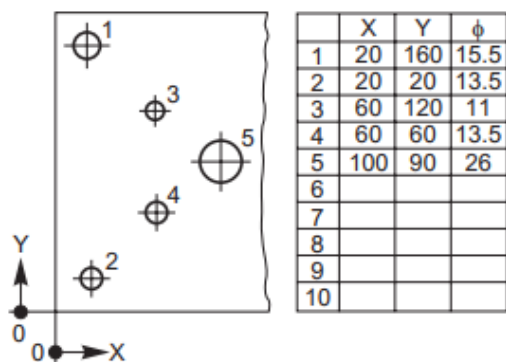


Fig. Co-ordinate dimensioning



## Special Indications

### Diameters

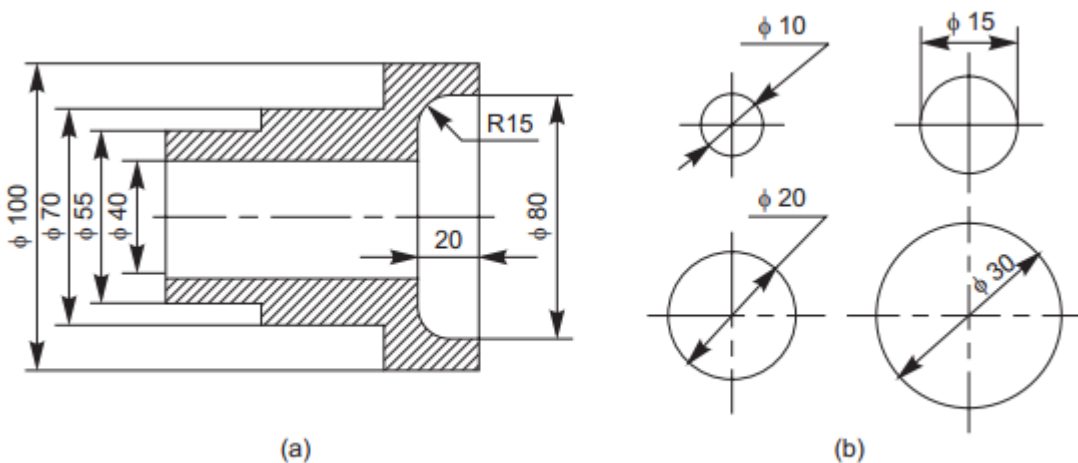


Fig. 2.48 Dimensioning of diameters

### Dimensioning of chords, arcs radii and angles

#### Equi-distant features

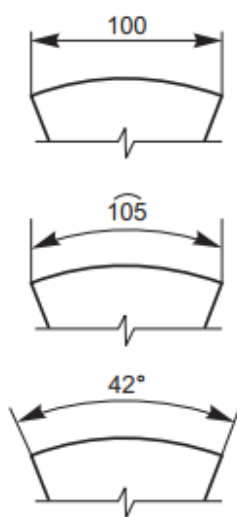


Fig. 2.49 Dimensioning of chords, arcs and angles

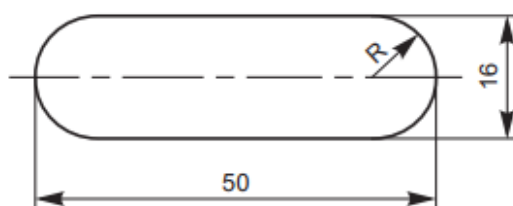


Fig. 2.49 Dimensioning of radius

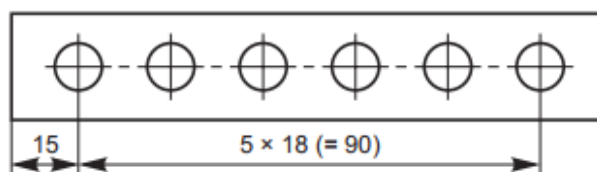


Fig. 2.50 Dimensioning equi-distant features

## Chamfer and countersunk

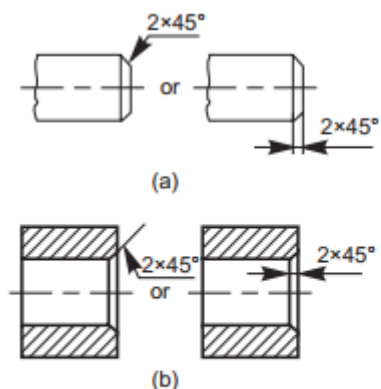


Fig. 2.55 Dimensioning chamfers

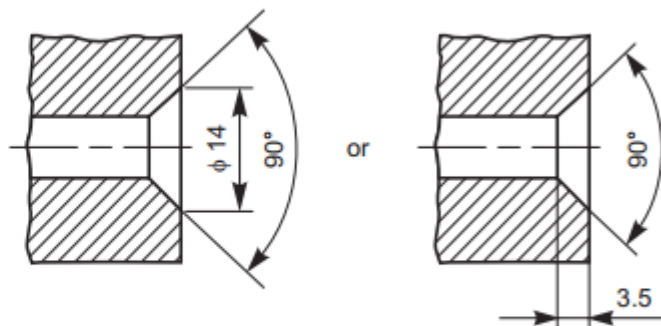
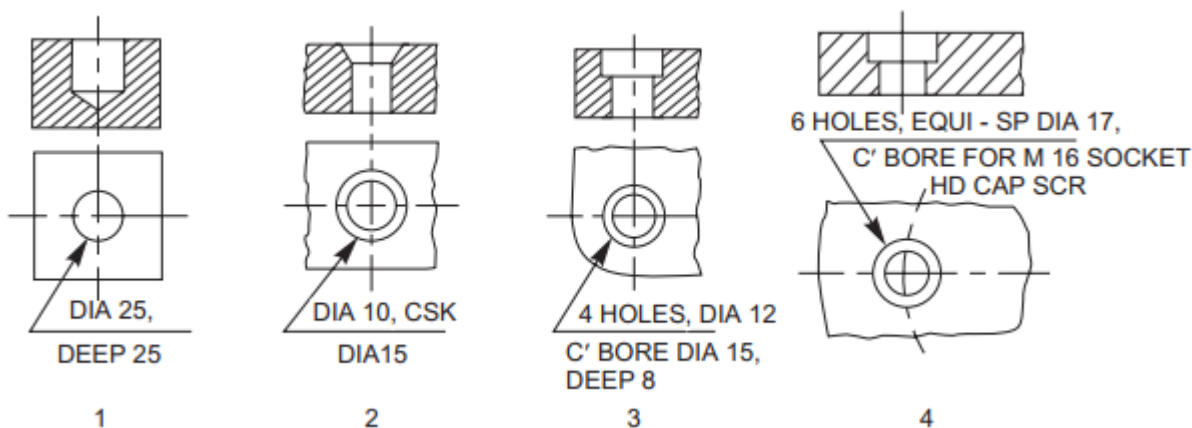


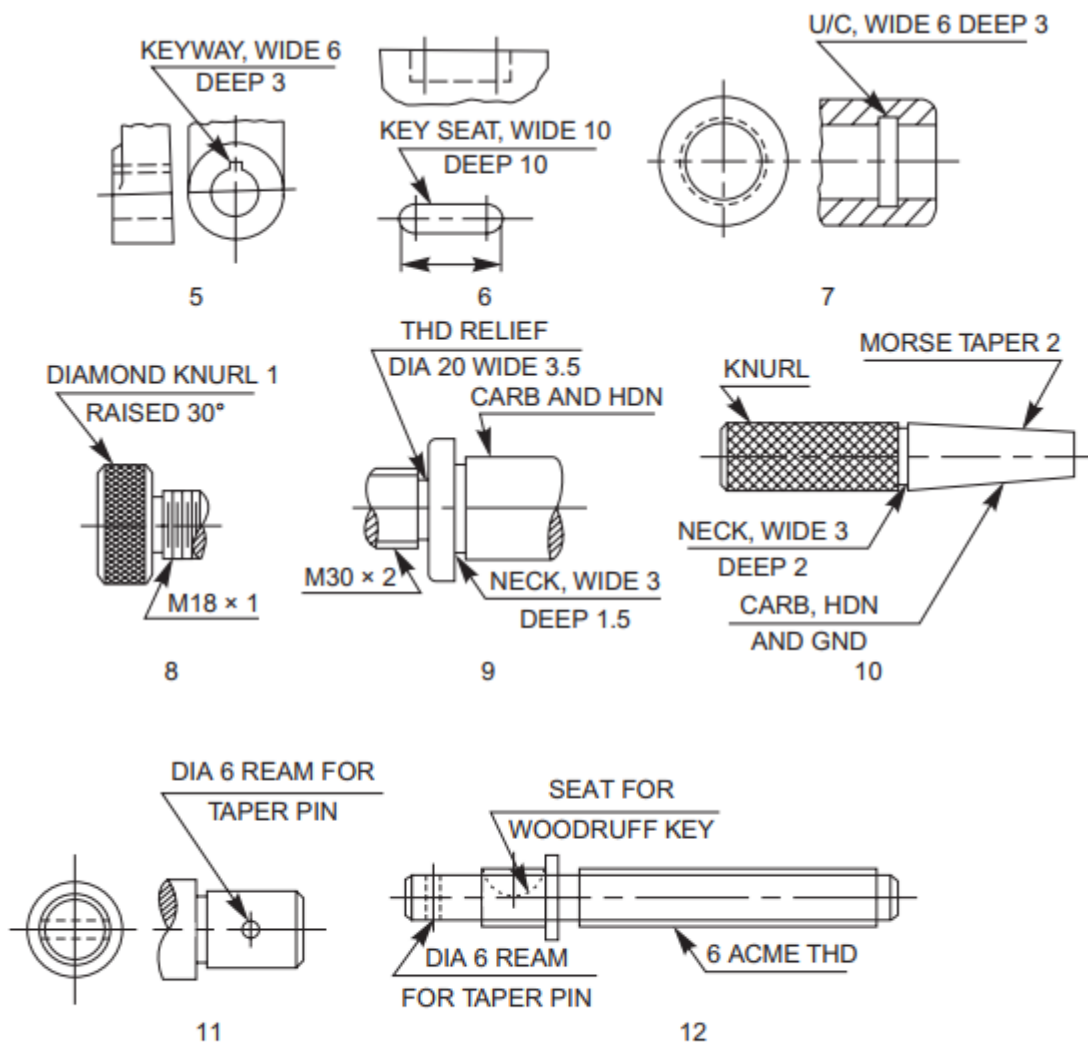
Fig. 2.56 Dimensioning countersunks

<https://www.youtube.com/watch?v=xjlx6L5SabY>

## Notes

Notes should always be written horizontally in capital letters and begin above the leader line and may end below also. Further, notes should be brief and clear and the wording should be standard in form. The standard forms of notes and the method of indication, for typical cases is shown in Fig. 2.55. The meaning of the notes is given in Table 2.8.





**Fig. 2.55** Method of indicating notes

**Table 2.8** Meaning of notes given in Fig. 2.55

<i>S.No.</i>	<i>Note</i>	<i>Meaning/Instruction</i>
1.	DIA 25 DEEP 25	Drill a hole of diameter 25 mm, to a depth of 25 mm.
2.	DIA 10 CSK DIA 15	Drill a through hole of diameter 10 mm and countersink to get 15 mm on top.
3.	4 HOLES, DIA 12 C BORE DIA 15 DEEP 8	Drill through hole of $\phi$ 12 mm, counterbore to a depth of 8 mm, with a $\phi$ 15 mm, the number of such holes being four.
4.	6 HOLES, EQUI-SP DIA 17 C BORE FOR M 16 SOCKET HD CAP SCR	Drill a through hole of $\phi$ 17 and counterbore to insert a socket headed cap screw of M 16. Six holes are to be made equi-spaced on the circle.
5.	KEYWAY, WIDE 6 DEEP 3	Cut a key way of 6 mm wide and 3 mm depth.
6.	KEY SEAT, WIDE 10 DEEP 10	Cut a key seat of 10 mm wide and 10 mm deep to the length shown.
7.	U/C, WIDE 6 DEEP 3	Machine an undercut of width 6 mm and depth 3 mm.
8.	(a) DIAMOND KNURL 1 RAISED 30° (b) M 18 $\times$ 1	Make a diamond knurl with 1 mm pitch and end chamfer of 30°. Cut a metric thread of nominal diameter 18 mm and pitch 1 mm.
9.	(a) THD RELIEF, DIA 20 WIDE 3.5 (b) NECK, WIDE 3 DEEP 1.5 (c) CARB AND HDN	Cut a relief for thread with a diameter of 20.8 mm and width 3.5 mm. Turn an undercut of 3 mm width and 1.5 mm depth Carburise and harden.
10.	(a) CARB, HDN AND GND (b) MORSE TAPER 2	Carburise, harden and grind. Morse taper No. 1 to be obtained.
11.	DIA 6 REAM FOR TAPER PIN	Drill and ream with taper reamer for a diameter of 6 mm to suit the pin specified.
12.	6 ACME THD	Cut an ACME thread of pitch 6 mm.

<https://www.youtube.com/watch?v=1Hm5Zyjmjac>





- a. The specification control drawing number is not a part number. The vendor part itself shall be identified by the vendor's identifying number.
- b. The assembly (or installation) drawing shall call out the part by the specification control drawing number. In the List of Material (parts list) of the drawing, the specification control drawing number shall be accompanied by the note “Vendor Part— see specification control drawing.” A specification control drawing shall be identified by the words “Specification Control Drawing” immediately above the Title block.
- c. A specification control drawing does not prevent procurement from multiple sources when the vendor part has been determined to be equivalent to other vendor parts by the Federal Cataloging Program, resulting in Federal Item Identification Number (FIIN) number assignment or when the part is manufactured by a licensee of the vendor.
- d. The preparation of specification control drawings can be avoided by procuring the vendor's manufacturing drawings. In the event the vendor claims proprietary rights and refuses to provide his manufacturing drawings, he shall be requested to furnish an outline drawing of his part sufficient to include the requirements stated above. When the vendor provides either type of drawings (i.e., manufacturing drawings or an outline drawing), the part number callout on the drawing shall be by the vendor's number.
- e. A specification control drawing shall not upgrade a vendor's part beyond the vendor's stipulations.

Page 94 of 129	Federal TVET Agency Author/Copyright	Machining II Prepare Basic (2D) Engineering Drawing Using CAD	Version 1 October 2019
----------------	---	---	---------------------------



<b>Self-Check - 2</b>	<b>Written Test</b>
-----------------------	---------------------

**Directions:** Answer all the questions listed below. Use the Answer sheet provided in the next page:

**Say true and false.**

1. Dimension is a numerical value expressed in appropriate units of measurement.
2. Dimensions should be placed parallel to their dimension lines.
3. Notes should always be written horizontally in capital letters
4. Specification control drawings are prepared to record the characteristics of a vendor-designed

**Note: Satisfactory rating - 2 and 4 points      Unsatisfactory - below 2 and 4 points**

You can ask you teacher for the copy of the correct answers.

Page 95 of 129	Federal TVET Agency Author/Copyright	Machining II Prepare Basic (2D) Engineering Drawing Using CAD	Version 1 October 2019
----------------	---	---	---------------------------



## Answer Sheet

Score = \_\_\_\_\_

Rating: \_\_\_\_\_

Name: \_\_\_\_\_

Date: \_\_\_\_\_

### Short Answer Questions

- 1.
- 2.
- 3.
- 4.





### 3.1 Blueprinting

#### Introduction

In many ways, learning to read a drawing is the same as learning to read a language. Blueprint is the common name of the copies taken from an original drawing, usually drawn on a tracing paper. The copies may be obtained by way of reprographic processes, viz., blueprinting, ammonia printing, xerox copying, copy of a photo film, etc., but the colour of the print has nothing to do with the name “blueprint”.

For blueprint reading and understanding the drawing, one must have a thorough knowledge of the principles of drawing and orthographic projections. The knowledge of various manufacturing processes and the sequence of operations required to obtain the finished shape, intended by the designer, also helps in interpreting the drawings.

In this module, the examples chosen help providing guidelines to enable students to understand the shape and size of a component, in the case of component drawings, and also its location, in the case of assembly drawings. While reading the drawings, the details such as shape, size, through dimensions, notes and material to be used, and additional notes to the workman on machining, surface finish, tolerances, etc., are to be noted carefully.

#### Examples

##### Rear tool post

Rear tool post is generally used on capstan lathes, mainly for parting-off operations. It is fixed on the cross-slide in the slots, provided at the rear side of the lathe. Study the drawing shown in Fig. 17.1 and answer the following:

1. What is the overall size of the tool post?  
— 102mm × 70mm × 62mm
2. How many bolts are provided for fixing the tool, and what is the size of each bolt?  
—3, M10
3. What type of tool can be used with it?  
— Parting tool

4. What is the maximum height of the tool holder?  
— 25mm
5. How many screws are provided to locate the tool?  
— 2
6. How is the tool holder fixed to the cross slide?  
— By 2 Nos. of M6 Hex. socket headed set screws
7. What is the purpose of the threaded hole marked 'X'?  
— For adjusting the tool height, by means of a screw
8. Explain the note—4 HOLES, M10.  
—There are three tapped holes in the body to clamp the tool in position by screws and the fourth tapped hole is at the bottom of the base. The size of the tap is 10mm.

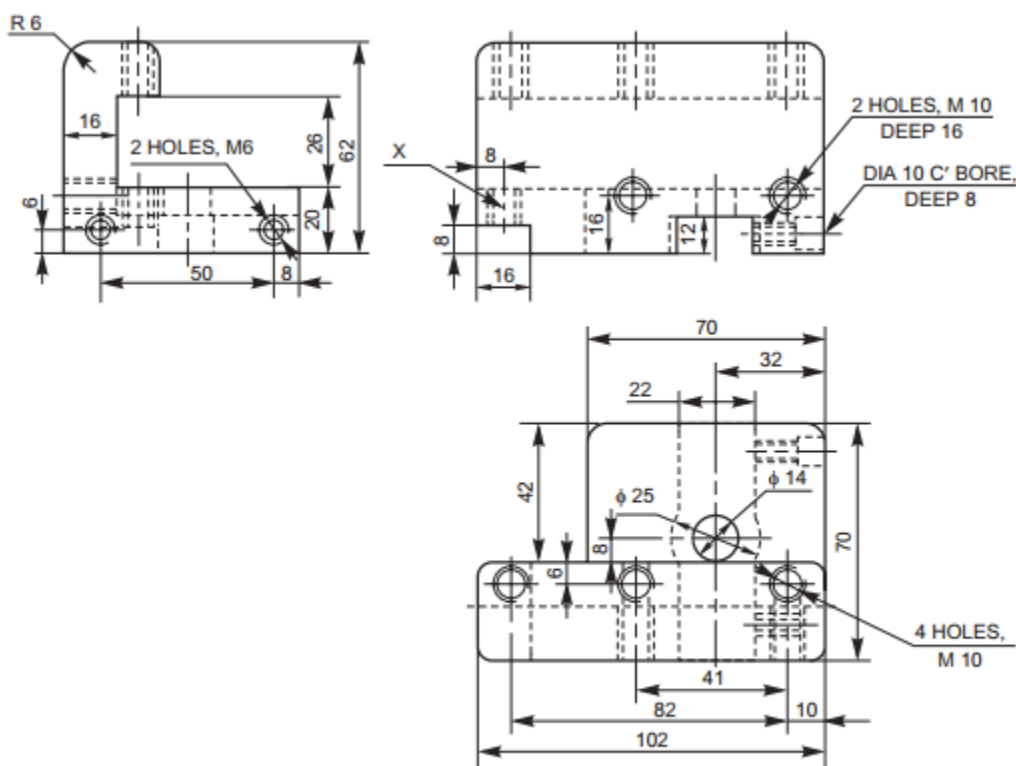


Fig. Rear tool post





<b>Self-Check - 3</b>	<b>Written Test</b>
-----------------------	---------------------

**Directions:** Answer all the questions listed below. Use the Answer sheet provided in the next page:

**Say true and false.**

1. Learning to read a drawing is the same as learning to read a language.
2. Blueprint is the drawing usually drawn on a tracing paper.

**Note: Satisfactory rating - 1 and 2 points      Unsatisfactory - below 1 and 2 points**

You can ask you teacher for the copy of the correct answers.



## Answer Sheet

Score = \_\_\_\_\_

Rating: \_\_\_\_\_

Name: \_\_\_\_\_

Date: \_\_\_\_\_

### Short Answer Questions

1.

2.



Operation Sheet- 1	Isometric and orthographic Drawing
--------------------	------------------------------------

### Techniques for Isometric Drawing

**Step 1-** Visualize the drawing

**Step 2-** select/ realise pictorial drawing

**Step 3 -** Identify layout of drawing sheets

**Step 4 -** Identify different types and thicknesses of lines on the drawing

**Step 5 –** carefully sketch the drawing

Operation Sheet- 2	Indicating dimensions, notes and specifications
--------------------	---

### Techniques for Indicating dimensions, notes and specifications

**Step 1-** Identify method of dimensioning

**Step 2-** Dimensions should be placed outside the view.

**Step 3 -** Dimensions should be taken from visible outlines rather than from hidden lines.

**Step 4 –** Dimensioning to a center line should be avoided except when the centre line passes through the center of a hole.

**Step 5 -** Each feature should be dimensioned once only on a drawing.

**Step 6 -** Dimensions should be placed on the view or section that relates most clearly to the corresponding features.

**Step 7 -** Each drawing should use the same unit for all dimensions, but without showing the unit symbol.

**Step 8 -** No more dimensions than are necessary to define a part should be shown on a drawing.

**Step 9 –** Complete dimensioning

Page 102 of 129	Federal TVET Agency Author/Copyright	Machining II Prepare Basic (2D) Engineering Drawing Using CAD	Version 1 October 2019
-----------------	---	---	---------------------------





# Foundry work

## Level-II

# Learning Guide-15

**Unit of Competence:** Preparing Basic (2D) Engineering Drawing Using

CAD

**Module Title:** Preparing Basic (2D) Engineering Drawing Using

CAD

**LG Code:** IND FDW 2 M04 LO1-LG-15

**TTLM Code:** IND FDW 2 M04 TTLM 0919v1

**LO 3: Prepare engineering parts list**

Page 104 of 129	Federal TVET Agency Author/Copyright	Machining II Prepare Basic (2D) Engineering Drawing Using CAD	Version 1 October 2019
-----------------	---	---	---------------------------





This learning guide is developed to provide you the necessary information regarding the following **content coverage** and topics:

- Identifying and organizing Component parts and material.
- Completing part lists records

This guide will also assist you to attain the learning outcome stated in the cover page. Specifically, **upon completion of this Learning Guide, you will be able to:**

- Component parts are identified and organized by component type and/or in accordance with company/customer requirements
- Drawings and/or parts lists **records** are completed in accordance with standard operating procedures

### Learning Instructions:

13. Read the specific objectives of this Learning Guide.
14. Follow the instructions described below 106 to 111.
15. Read the information written in the information “Sheet 1, and Sheet 2”.
16. Accomplish the “Self-check 1, and Self-check t 2” **in page -111 and 114** respectively.
17. If you earned a satisfactory evaluation from the “Self-check” proceed to “Operation Sheet 1, and Operation Sheet 2” **in page -115 & 116.**
18. Do the “LAP test” **in page – 117** (if you are ready).



## 1.1 Component types and parts.

### 1.1.1 Part Drawing

#### Introduction

The first step in developing a new machine is the preparation of design assembly drawings. After the drawing is analyzed thoroughly, final assembly drawings are made from these drawings. To facilitate the manufacture of the unit, individual parts of the unit are to be produced first, which requires the preparation of part drawings. These are prepared from the final assembly drawings. The part drawing must contain all the information required such as size and shape description, dimensions, notes, suitable material, etc., to enable the student to understand the functional aspects of the unit.

In the classroom training process, students are given final assembly drawings from which they are required to prepare part drawings. The assembly drawings may contain a few details only, such as center distances, locating dimensions and overall dimensions. However, the student is expected to use the assembly drawing as a guide to prepare the part drawings. While doing so, the detailed dimensions to make part drawings can be transferred directly from the assembly drawings, according to the scale to which they are made.

The students are expected to read the assembly drawings carefully and visualize the shapes of individual parts, before making part drawings.

The steps to be followed to prepare part drawings from the assembly drawing are:

1. Understand the assembly drawing thoroughly, by referring to the parts list and the different orthographic views of the unit.
2. Study the functional aspect of the unit as a whole. This will enable to understand the arrangement of the parts.
3. Visualize the size and shape of the individual components.

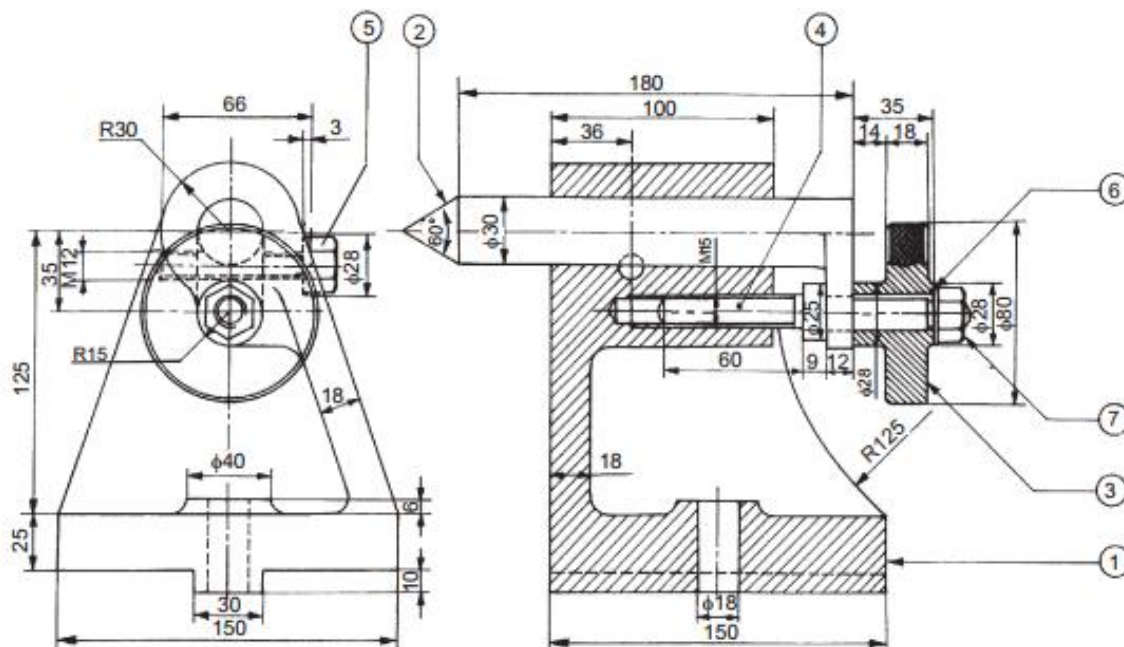


4. As far as possible, choose full scale for the drawing. Small parts and complicated shapes may require the use of enlarged scales so that their presentation will have a balanced appearance.
5. Select the minimum number of views required for describing each part completely. The view from the front selected must provide maximum information of the part.
6. The under mentioned sequence may be followed for preparing different views of each part :
  - (i) Draw the main center lines and make outline blocks, using the overall dimensions of the views.
  - (ii) Draw the main circles and arcs of the circles.
  - (iii) Draw the main outlines and add all the internal features.
  - (iv) Cross-hatch the sectional views.
  - (v) Draw the dimension lines and add dimensions and notes.
7. Check the dimensions of the mating parts.
8. Prepare the parts list and add the title block.

#### Redraw Part drawing

Disassemble the parts of the milling machine tail-stock, shown on the fig below.

Page 107 of 129	Federal TVET Agency Author/Copyright	Machining II Prepare Basic (2D) Engineering Drawing Using CAD	Version 1 October 2019
-----------------	---	---	---------------------------



Parts list

Part No.	Name	Matl.	Qty.
1	Body	CI	1
2	Centre	Case hardened alloy steel	1
3	Hand wheel	Cast steel	1
4	Screw	MS	1
5	Screw	MS	1
6	Washer	MS	1
7	Nut	MS	1

Fig. Milling machine tail-stock



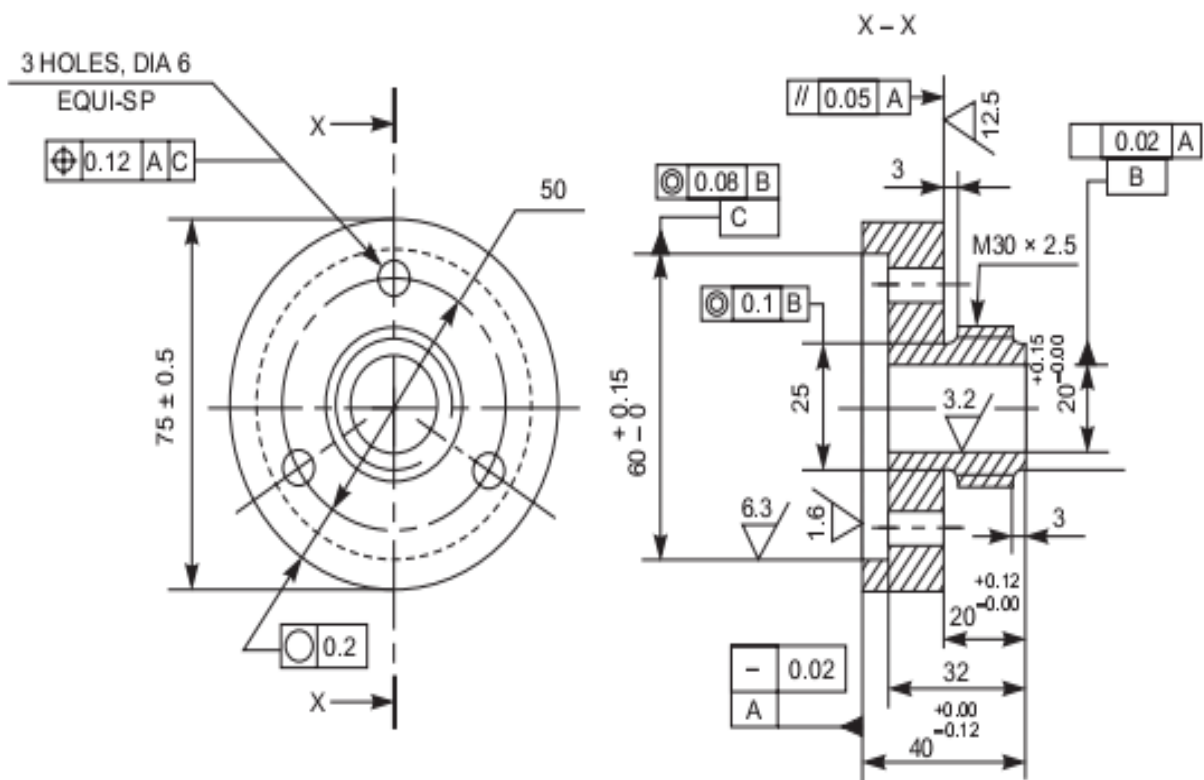
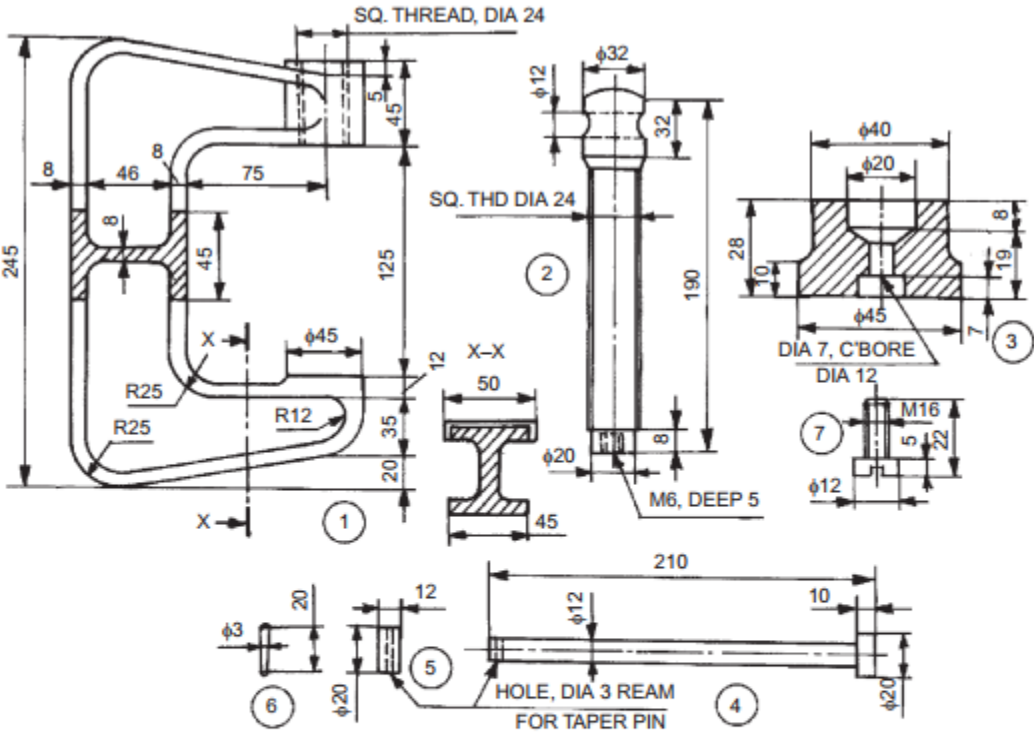


Fig. 5.4 Production drawing

<b>Self-Check -1</b>	<b>Sketch Test</b>
----------------------	--------------------

**Directions:** Answer all the questions listed below. Use the Answer sheet provided in the next page:

**Redraw part drawing**



Parts list

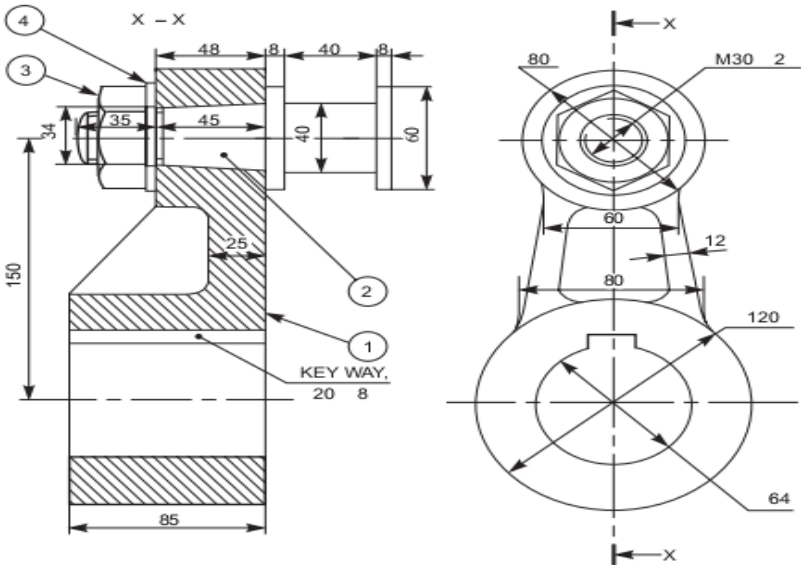
Sl. No.	Name	Matl.	Qty.
1	Frame	CI	1
2	Screw	MS	1
3	Pad	MS	1
4	Tommy bar	MS	1
5	Collar	MS	1
6	Pin	MS	1
7	Cap screw	MS	1

**Fig. 18.48** C-clamp

<b>Information Sheet-2</b>	<b>Completing part lists records</b>
----------------------------	--------------------------------------

**2.1 Complete drawings and/or parts lists records**

A drawing that shows the various parts of a machine in their correct working locations is an assembly drawing. See Fig. below:



**Parts List**

Part No.	Name	Material	Qty
1	Crank	Forged Steel	1
2	Crank Pin	45C	1
3	Nut	MS	1
4	Washer	MS	1

Fig. 9 Assembly drawing

**2.2 Assembly Drawing**

**Introduction**

A machine is an assembly of various links or parts. It is necessary to understand the relation between the various parts of the unit for the purpose of design and production. An assembly drawing is one which represents various parts of a machine in their working position. These drawings are classified as design assembly drawings, working assembly drawings, sub-assembly drawings, installation assembly drawings, etc. An assembly drawing made at the design stage while developing a machine is known as design assembly drawing. It is made to a larger scale so that the required changes or modifications may be thought of by the designer, keeping in view both the functional



requirement and aesthetic appearance. Working assembly drawings are normally made for simple machines, comprising small number of parts. Each part is completely dimensioned to facilitate easy fabrication. A sub-assembly drawing is an assembly drawing of a group of related parts which form a part of a complicated machine. Thus, a number of such sub-assembly drawings are needed to make a complete unit. An installation assembly drawing reveals the relation between different units of a machine, giving location and dimensions of few important parts. The final assembly drawings are prepared from design assembly drawings or from the working drawings (component drawings). The class-room exercises are designed to train the students to master fundamentals of machine drawing, such as principles of drawing, orthographic projections, etc. In addition, the student will understand the relation between the different parts of the components and working principles of the assembled unit. The following steps may be made use of to make an assembly drawing from component drawings:

1. Understand the purpose, principle of operation and field of application of the given machine. This will help in understanding the functional requirements of individual parts and their location.
2. Examine thoroughly, the external and internal features of the individual parts.
3. Choose a proper scale for the assembly drawing.
4. Estimate the overall dimensions of the views of the assembly drawing and make the outline blocks for each of the required view, leaving enough space between them, for indicating dimensions and adding required notes.
5. Draw the axes of symmetry for all the views of the assembly drawing.
6. Begin with the view from the front, by drawing first, the main parts of the machine and then adding the rest of the parts, in the sequence of assembly.
7. Project the other required views from the view from the front and complete the views.
8. Mark the location and overall dimensions and add the part numbers on the drawing.
9. Prepare the parts list.
10. Add the title block.

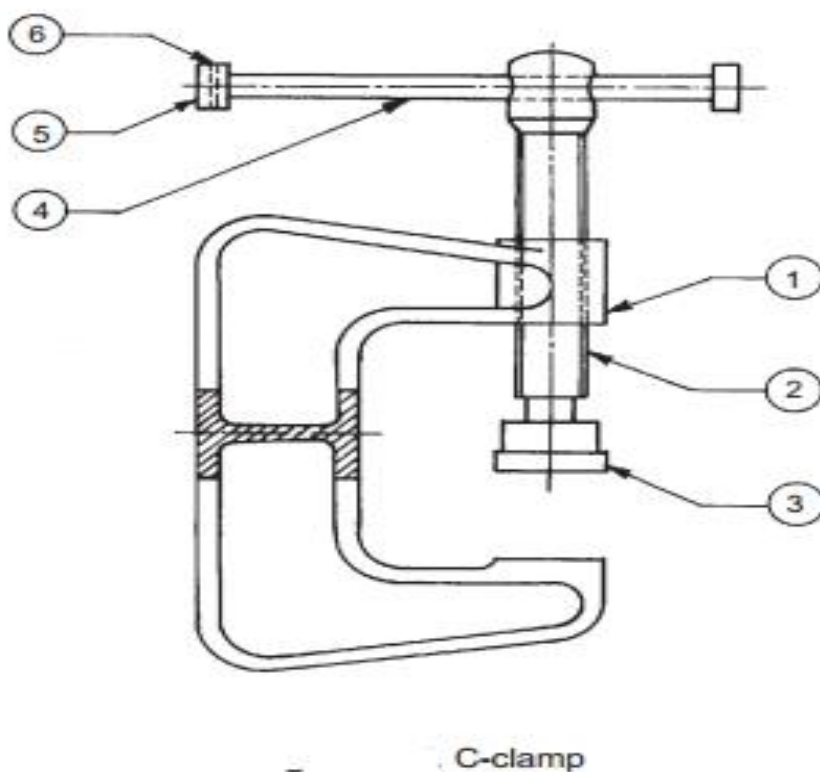
**NOTE:** It is not advisable to complete one view before commencing the other. The better method is to develop all the required views simultaneously.

<b>Self-Check -2</b>	<b>Sketch</b>
----------------------	---------------

**Directions:** Answer all the questions listed below. Use the Answer sheet provided in the next page:

Draw the assemble drawing of the object.

As refer to the part dimension of the self-check 1





Operation Sheet- 1	Identifying and organizing Component parts and material.
--------------------	--

**Techniques to prepare part drawings from the assembly drawing are:**

**Step 1-** Understand the assembly drawing thoroughly, by referring to the parts list and the different orthographic views of the unit.

**Step 2-** Study the functional aspect of the unit as a whole.

**Step 3-** Visualize the size and shape of the individual components.

**Step 4-** As far as possible; choose full scale for the drawing.

**Step 5-** Select the minimum number of views required for describing each part completely.

**Step 6-** Preparing different views of each part.

**Step 7-** Check the dimensions of the mating parts.

**Step 8-** Prepare the parts list and add the title block.



Operation Sheet- 2	Identifying and organizing Component parts and material.
--------------------	--

## Techniques to make an assembly drawing from component drawings

The following steps may be made use of

**Step 1-** Understand the purpose, principle of operation and area of application of the given machine part.

**Step 2-** Examine thoroughly, the external and internal features of the individual parts.

**Step 3-** Choose a proper scale for the assembly drawing.

**Step 4-** Estimate the overall dimensions of the views of the assembly drawing and make the outline blocks for each of the required view, leaving enough space between them, for indicating dimensions and adding required notes.

**Step 5-** Draw the axes of symmetry for all the views of the assembly drawing.

**Step 6-** Begin with the view from the front, by drawing first, the main parts of the machine and then adding the rest of the parts, in the sequence of assembly.

**Step 7-** Project the other required views from the view from the front and complete the views.

**Step 8-** Mark the location and overall dimensions and add the part numbers on the drawing.

**Step 9-** Prepare the parts list.

**Step 10-** Add the title block.

Page 116 of 129	Federal TVET Agency Author/Copyright	Machining II Prepare Basic (2D) Engineering Drawing Using CAD	Version 1 October 2019
-----------------	---	---	---------------------------

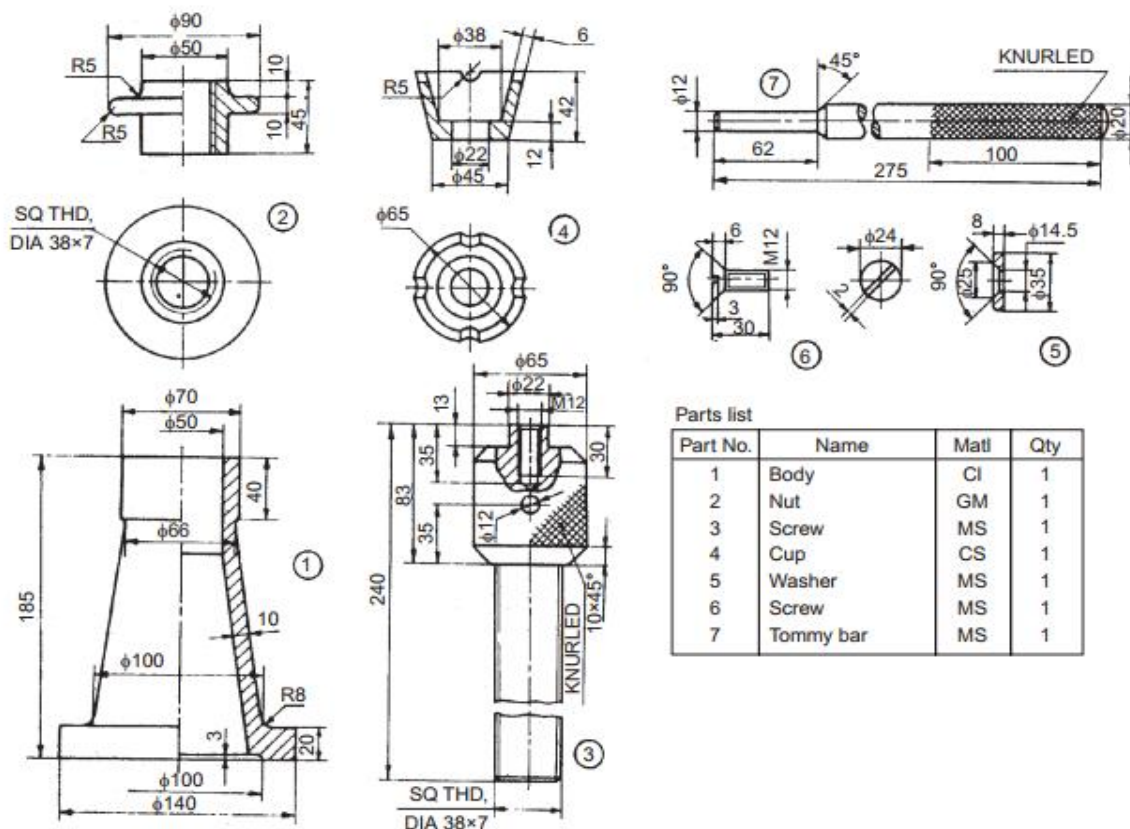
<b>LAP Test</b>	<b>Practical Demonstration</b>
-----------------	--------------------------------

Name: \_\_\_\_\_ Date: \_\_\_\_\_

Time started: \_\_\_\_\_ Time finished: \_\_\_\_\_

**Instructions:** Given necessary templates, tools and materials you are required to perform the following tasks within 8 hours.

1. Redraw the part drawing and assemble drawing with the complete dimensioning of the following object.



Parts list

Part No.	Name	Matl	Qty
1	Body	CI	1
2	Nut	GM	1
3	Screw	MS	1
4	Cup	CS	1
5	Washer	MS	1
6	Screw	MS	1
7	Tommy bar	MS	1

Screw jack



# Foundry work

## Level-II

# Learning Guide-16

**Unit of Competence:** Preparing Basic (2D) Engineering Drawing Using CAD

**Module Title:** Preparing Basic (2D) Engineering Drawing Using CAD

**LG Code:** IND FDW 2 M04 LO2-LG-16

**TTLM Code:** IND FDW 2 M04 TTLM 1019v1

## LO 4: Issue approved drawing

Page 118 of 129	Federal TVET Agency Author/Copyright	Machining II Prepare Basic (2D) Engineering Drawing Using CAD	Version 1 October 2019
-----------------	---	---	---------------------------



<b>Instruction Sheet</b>	<b>Learning Guide #16</b>
--------------------------	---------------------------

This learning guide is developed to provide you the necessary information regarding the following **content coverage** and topics:

- Copying and issuing drawing and norm parts lists.
- Storing and cataloguing drawings and norm parts lists.

This guide will also assist you to attain the learning outcome stated in the cover page. Specifically, **upon completion of this Learning Guide, you will be able to:**

- Approved drawing and/or parts lists are copied and **issued** to relevant personnel in accordance with standard operating procedures.
- Approved drawings and/or parts lists are stored and catalogued in accordance with standard operating procedures

#### **Learning Instructions:**

19. Read the specific objectives of this Learning Guide.
20. Follow the instructions described below 120 to 122.
21. Read the information written in the information “Sheet 1 and Sheet 2”.
22. Accomplish the “Self-check 1, and Self-check 2” **in page - 123, and 125** respectively.
23. If you earned a satisfactory evaluation from the “Self-check” proceed to “Operation Sheet 1, and Operation Sheet 2” **in page -126.**
24. Do the “LAP test” **in page – 127** (if you are ready).

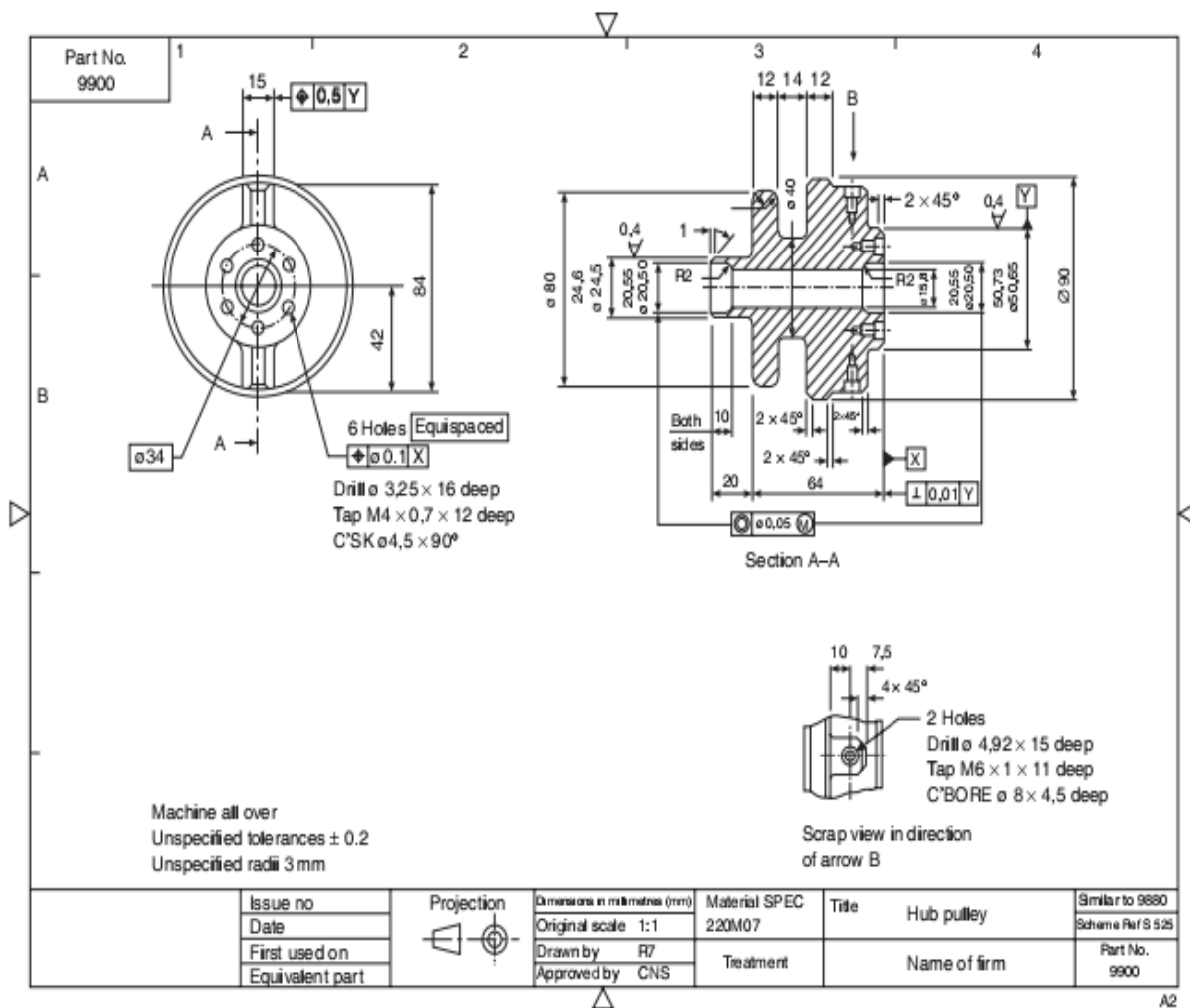
Page 119 of 129	Federal TVET Agency Author/Copyright	Machining II Prepare Basic (2D) Engineering Drawing Using CAD	Version 1 October 2019
-----------------	---	---	---------------------------

<b>Information Sheet-1</b>	<b>Copying and issuing drawing and norm parts lists.</b>
----------------------------	--

### 1.1 Copy Approved drawing.

Completed drawings are usually presented on company standard sheets. Sizes, areas and designation are given at the standard level. The layout of a typical sheet contains information required for identification, administration and interpretation and a company could design several types of standard sheets, particularly appropriate to their products.

If drawings are produced manually, then the drawing sheets may be supplied with printed borders and blocks containing relevant notes and headings.







## 1.2 Issue approved drawing

Approved drawing and/or parts lists need to be copied and **issued** to relevant personnel in accordance with standard operating procedures.

Drawings issued are in the form of:

- hard copy
- photographic
- slide or transparency form

The tabulated data of drawing issue form.

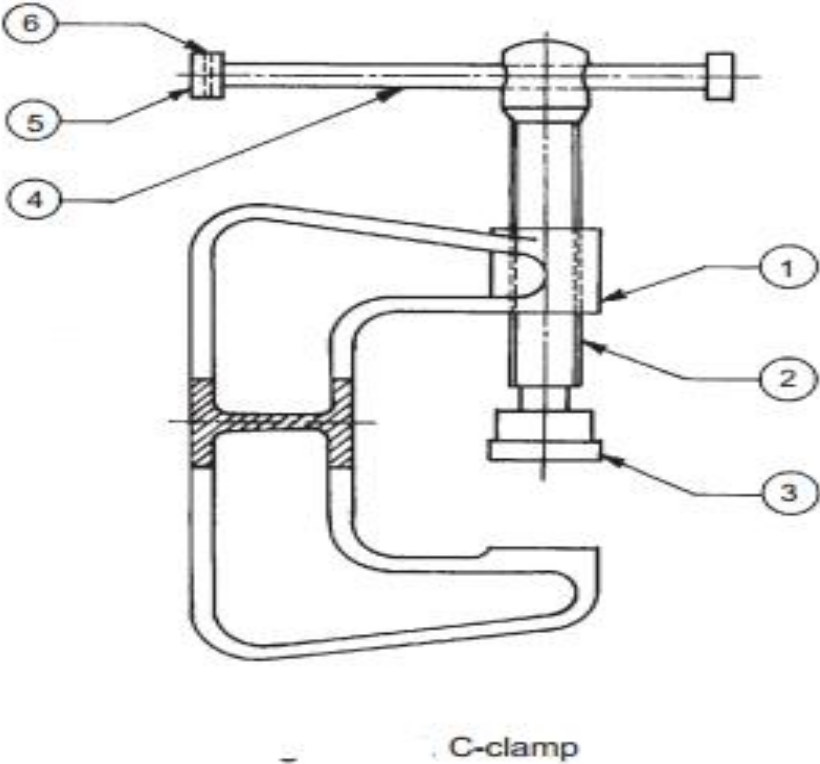
St. Catherine's House, Tel : +353 51 876 855 Catherine Street, Fax : +353 51 876 828 Waterford. Email : info@Waterford.MORce.ie		2B Richview Office Park, Tel : +353 1 2602655 Clonskeagh, Fax : +353 1 2602660 Dublin 14. Email : info@MORce.ie	Sheet No.  <b>01</b>	
DRAWING ISSUE FORM				
Job No :	Job :	Date Issued		
W10100	New Slipway & Associated Works at Ferrybank, Wexford Harbour	Day	05	
		Month	09	
		Year	12	
Drawing No.	Drawing Title	Revision No.		
100	Proposed Site Plan	P		
101	Proposed Sections 1-1 to 5-5	P		
102	Proposed Sections 6-6 to 11-11	P		
103	Proposed Lease Map	P		
104	Outfall Details	P		
105	Admiralty Chart showing Location of Proposed Slipway	P		
106	Site Location Map (1:10560)	P		



<b>Self-Check - 1</b>	<b>Write test</b>
-----------------------	-------------------

**Directions:** Answer all the questions listed below. Use the Answer sheet provided in the next page:

Copying and issuing the assemble drawing of the object sketched on learning outcome above LO 3.

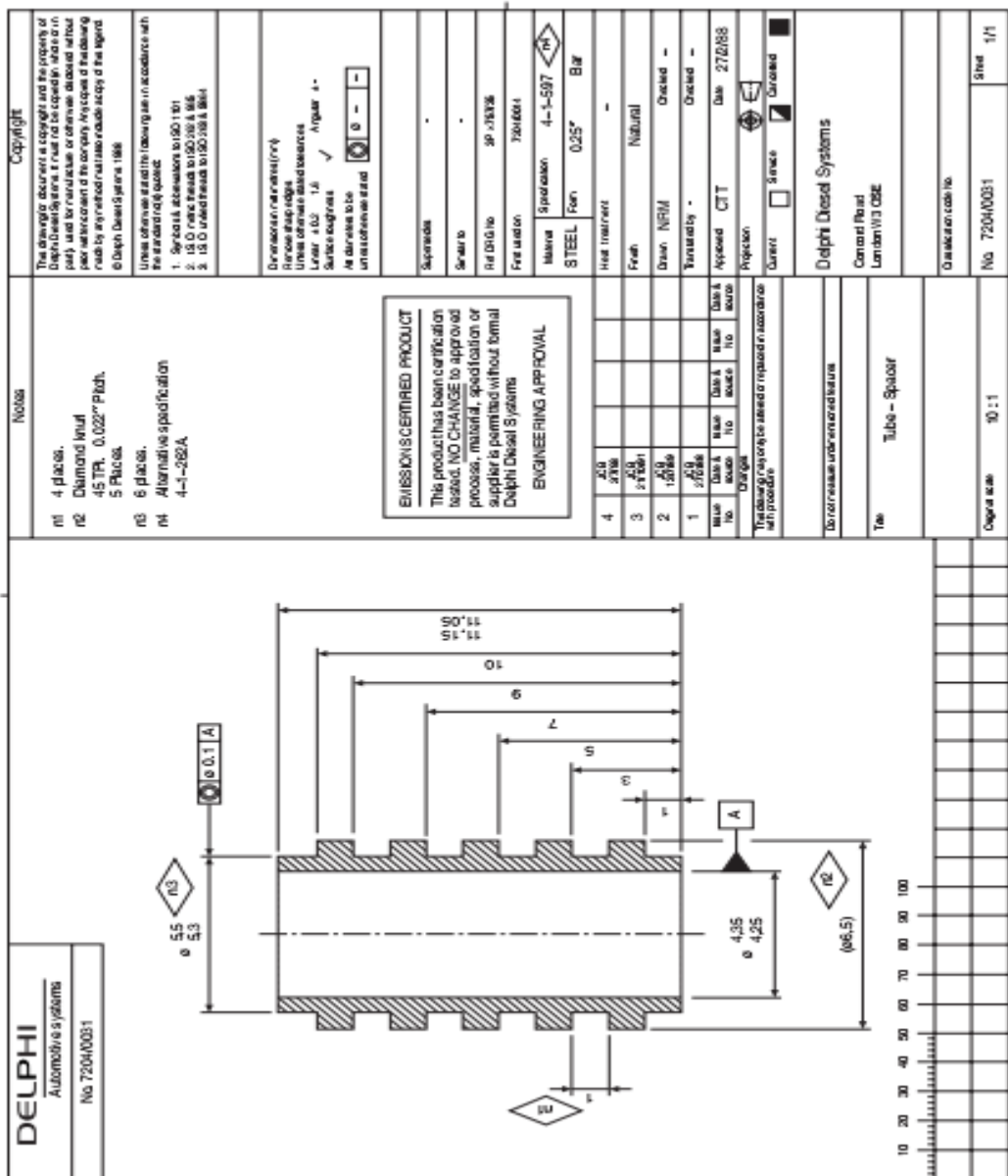


# Information Sheet-2

## Storing and cataloguing drawings and norm parts lists

### 2.1 store and catalogue Approved drawings

Figures below clearly show that documentation can occupy much of the sheet area. The space provided for basic and supplementary information will be decided by the company; its actual position on the sheet may vary with the sheet size.



<b>Self-Check - 2</b>	<b>Write test</b>
-----------------------	-------------------

**Directions:** Answer all the questions listed below. Use the Answer sheet provided in the next page:

**Store and catalogue the approved drawing by printing and copying.**

ITEM	DESCRIPTION	MATERIAL	QTY	PART NUMBER
6	Hex Bolt	Steel, Mild	4	ANSI B18.2.3.5M - M10 x 1.5 x 20
5	ROLLER	Cast Steel	1	RA_01-3
4	BUSH	Bronze, Soft Tin	2	RA_01-5
3	SPINDLE	Alloy Steel	1	RA_01-4
2	BRACKET	Cast Iron	2	RA01-2
1	BASE	Cast Iron	1	RA_01-1

	DRAWN	TITLE
	CHECKED	<b>ROLLER ASSEMBLY</b>
	DATE	SCALE 1:2
		DRG. NO.



<b>Operation Sheet- 1</b>	<b>Copying and issuing drawing and norm parts lists.</b>
---------------------------	--

Step 1- Reissue the sketch, from the designer.

Step 2- Print or copy the drawing.

Step 3- Make the catalog

Step 4- Store on appropriate cabinet

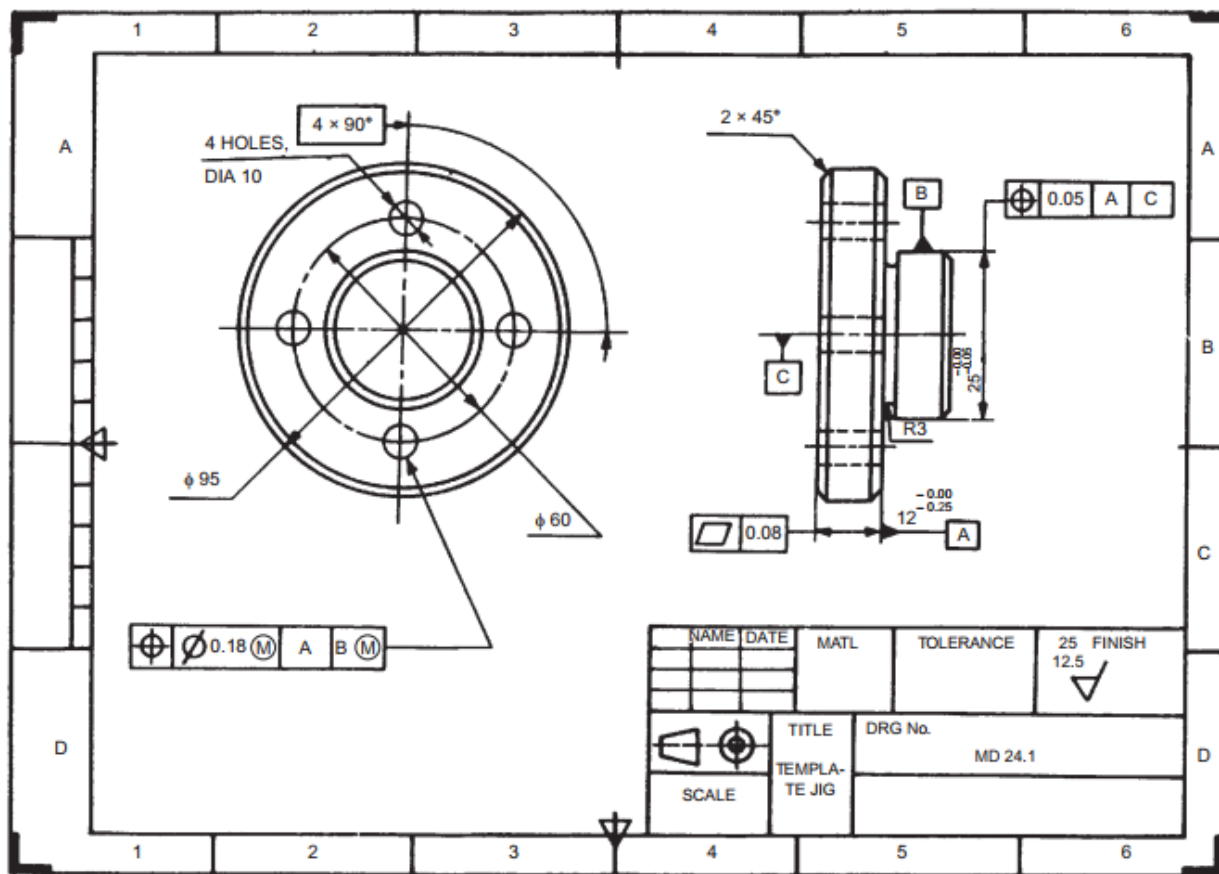
<b>LAP Test</b>	<b>Practical Demonstration</b>
-----------------	--------------------------------

Name: \_\_\_\_\_ Date: \_\_\_\_\_

Time started: \_\_\_\_\_ Time finished: \_\_\_\_\_

**Instructions:** Given necessary templates, tools and materials you are required to perform the following tasks within 1 hours.

**Storing, copying and issuing drawing according to standard.**





## Reference

1. Machine Drawing- P.S. Gill, S.K. Kataria & Sons, 17th Edition, 2012.
2. Machine Drawing- Dhawan, S.Chand Publications, 1st Revised Edition, 1998.
3. Machine Drawing – Ajeet Singh, McGraw Hill, 2012
4. Machine Drawing- Luzzader, PHI Publishers, 11th Edition.
5. Textbook of Machine Drawing-K.C.John, 2009, PHI learning, 1st Edition.
6. Machine Drawing- DR.K.L. Narayana, Dr. P.Kannaiah, K. Venkata Reddy, 3th Edition, 2006.

Page 128 of 129	Federal TVET Agency Author/Copyright	Machining II Prepare Basic (2D) Engineering Drawing Using CAD	Version 1 October 2019
-----------------	---	---	---------------------------





<b>NO</b>	<b>Name</b>	<b>Qualification</b>	<b>Region</b>	<b>E-mail</b>
1	Mohammed Abdela	A /MSc/	Dire Dewa	
2	Waliyi Bena	A /MSc/	Oromia	
3	Elias Zemenu	A /MSc/	Somali	
4	Gurmu Mulatu	A /MSc/	Adis Ababa	
5	Muluneh Negussie	A /BSc/	Amhara	
6	Teshome W/Yuhanis	A /MSc/	Debub	
7	Solomon Aderaw	A /BSc/	Amhara	
8	Wakweya Tolera	A /MSc/	Oromiya	